

# Salvatore Vitale

# How to Secure a Country

Ein Handbuch

A manual





# Salvatore Vitale How to Secure a Country

[ DE ]

Fotostiftung Schweiz, Winterthur,  
23. Februar bis 26. Mai 2019

Verfolgt man die weltweiten Nachrichten, scheinen Bedrohungen allgegenwärtig. Naturereignisse, Migrationsbewegungen und Cyberangriffe haben frühere, vor allem militärische Bedrohungsszenarien abgelöst und zu einer neuartigen Risikoeinschätzung geführt. Wie reagieren staatliche und private Akteure auf diese sich wandelnde Herausforderung? Wie gewährleisten sie die Sicherheit ihrer Bürger – dieses wertvolle Gut, das ebenso ein Grundbedürfnis wie ein Milliarden-geschäft ist? Und wie viel Freiheit sind wir bereit, für unsere Sicherheit aufzugeben? Die Schweiz gilt als eines der sichersten Länder der Welt und als ein Musterbeispiel für Effizienz. Die Frage, wie sie sich gegen alle Arten von Risiken, Gefahren und Bedrohungen abzusichern versucht, hat Salvatore Vitale (geb. 1986 in Palermo, in Lugano und Zürich lebend) zu einem visuellen Forschungsprojekt bewogen. Zwischen 2014 und 2018 hat er untersucht, wie Schutz- und Präventionssysteme unseren Alltag, unsere Verhaltensweisen und unser Denken durchdringen. Das Projekt reflektiert und verbildlicht die Herstellung von Sicherheit (und damit auch von Unsicherheit) durch Fotos, Texte und Datenvisualisierungen.

## EINE KULTUR DER PRÄVENTION UND ABSICHERUNG

Als Salvatore Vitale 2005 in die Schweiz übersiedelte und sich in Lugano niederliess, war er überrascht, wie Fragen der Sicherheit hierzulande verhandelt und gehandhabt werden. Als das Schweizer Volk 2014 die Eidgenössische Volksinitiative «Gegen Masseneinwanderung» guthiess, war er – selbst als Immigrant in diesem Land lebend – irritiert. Er verspürte die Notwendigkeit, das Phänomen der Sicherheit und seiner diskursiven und institutionellen Rahmenbedingungen zu erforschen. Worin bestehen die tiefer liegenden Motive einer politischen Debatte, bei der Identität, Ausgrenzung, Schutz und Sicher-

heit als Themen miteinander verschmelzen? Sein daraus erwachsenes Langzeitprojekt «How to Secure a Country» versucht die scheinbar obsessive Beschäftigung mit Sicherheit sichtbar zu machen: die Vorkehrungen, Einstellungen, Infrastrukturen, Codes und Protokolle, die sowohl im individuellen Verhalten als auch in der politischen Diskussion zum Beispiel zu Themen wie Migration zu beobachten sind.

Salvatore Vitales Untersuchung geht dabei vom institutionellen Netzwerk aus – Polizei, Militär, Zoll- und Migrationsbehörden, Wetterdienste, IT-Unternehmen sowie Forschungsstellen für Robotik und Künstliche Intelligenz. Das Ziel, die teilhabenden Akteure zu identifizieren, den Zugang zu ihnen zu erlangen und sie fotografisch zu dokumentieren, offenbarte sich jedoch rasch als Herausforderung. Denn nicht nur sind die Bedrohungen – reale oder wahrgenommene – oft unsichtbar und schwer fassbar. Auch die dagegen entwickelten Präventions- und Schutzschilde sind es. Oft handelt es sich dabei um standardisierte Handlungsabläufe und Wegeleitungen, Organisationsmodelle und Netzwerke, die abstrakt, nüchtern und gesichtslos sind. Dennoch – so legt die fotografische Arbeit nahe – manifestiert sich die Essenz dieses Sicherheitsapparats als ästhetisch wahrnehmbare Disposition, die mit den Mitteln der Fotografie erforscht und vermittelt werden kann. Das Projekt interessiert sich so zum Beispiel für die Untersuchung von Fragen wie: Warum machen sich die Schweizer Streitkräfte Gedanken über das jährliche Sorgenbarometer? Wie funktioniert die integrierte Grenzverwaltung? Was hat das Réduit mit Bitcoin und Cyber-Sicherheit zu tun? Und was bedeutet Predictive Policing in der Polizeiarbeit?

Dank einer aktiven Zusammenarbeit mit verschiedenen Spezialisten und Forschern gelingt es Salvatore Vitale, die Komplexität der Schweizer Sicherheitsindustrie offenzulegen. Durch sie erhielt er Zugang zu Orten, die ansonsten abgeschottet sind. So vermag er die oftmals abstrakte Erzeugung von Sicherheit auf eine konkrete Weise erlebbar zu machen – seine Arbeit leistet eine Art Kartographierung dessen, was man als öffentlich-privaten Sicherheitskomplex der Schweiz bezeichnen könnte. Salvatore Vitales Vorhaben positioniert sich somit als zeitgemässer künstlerischer Beitrag zu einer Debatte in einer Gesellschaft, die sich, zumindest in der Wahrnehmung, mit wachsenden Bedrohungen konfrontiert sieht. Mit seinem Werk schaltet er sich ebenso in eine gegenwärtige politische Debatte in der Schweiz ein, bei der es etwa um Schweizer Waffenexporte und die Privatsphäre der Bürger geht.

→

# Salvatore Vitale How to Secure a Country

[ EN ]

Fotostiftung Schweiz, Winterthur,  
23rd of February until 26th of May 2019

A SWISS PUBLIC-PRIVATE  
SECURITY COMPLEX

The project explores visually the ways in which social, political and psychological phenomena, which are most of the time invisible and somewhat elusive, become stabilized and therefore also visible through standard operating procedures and protocols. By tracing networks connecting the activities of data storage and insurance companies, weather forecasting services as well as the police, the military, or state-run organizations related to customs and migration, it traces and visually maps what could be referred to as a Swiss public-private security complex.

Vitale's goal was to capitalize on the actual fluidity and abstractness of the country's security measures and to photographically re-appropriate and re-code the "matter-of-factness" of the instruction manuals and protocols found in bureaucratic procedures. In this way, its paradoxical nature becomes apparent by looking at how "clear-cut" solutions are applied to what are, in fact, often highly fleeting phenomena. It means to trace and render visible the complexities that lie behind the Swiss security industries by providing a view from the inside thanks to an active collaboration with its actors and institutions.

Based on the above methods, the project makes it possible to experience the sometimes hidden and often abstract creation of security in a tangible way.

## A CULTURE AND ECONOMY BASED ON PREVENTION AND SECURITIZATION

When moving to Lugano in 2005, Vitale was often surprised and fascinated, how issues pertaining to security were discussed and portrayed differently to his previous context. But when in 2014 the Swiss electorate voted in favour of a popular referendum termed "Gegen Masseneinwanderung" (against mass immigration), which was aimed at curbing migration to Switzerland, Salvatore Vitale, himself living as an immigrant in that country, was also irritated and felt the need to research the phenomenon of security and its discursive and institutional framings. This, in order to comprehend where the deeper motives and roots for the political discourses, which often conflated identity, exclusion, protection, and security originated. He, therefore, set out to understand the seeming obsession with security and its concomitant attitudes, behaviour, codes, and protocols, observed both in individual practices, but also in public political discourses regarding the framing of security and migration. In order to achieve this, he visually explored the institutions, infrastructures and social processes that make up the Swiss security complex.

→

Switzerland is well-known as one of the safest countries on earth and as a prime example of efficiency and efficacy. But how do state and private actors ensure this valuable commodity, which is as much a basic need as it is a billion-dollar business? And how much freedom are we as citizens willing to give up for our security? Between 2014 and 2018, Salvatore Vitale (born 1986 in Palermo, lives in Lugano and Zurich) set out on a visual research project, to discover the central underlying tenets for such a country to evolve, exist and endure. One of the central conditions he made out is the development of a culture based on securing, protecting, insuring and preventing, which is supported by the presence and production of national security.

In order to do this, Vitale investigated the social and technological mechanisms underlying this preventive and defensive shield and takes a close look at the various institutional protagonists involved—police, military, customs and migration authorities, weather services, IT companies, and research institutions for robotics and artificial intelligence. He proposes to find these mechanisms in sets of embodied and often internalized individual and collective routines and practices, which support the production of systemic state-wide national security. The project is for example interested in exploring and visualizing questions like: Why do the Swiss armed forces worry about the annual worry barometer? How does integrated border management work? What does the Réduit have to do with bitcoin and cyber-security? Or what is predictive policing? It positions itself as a contemporaneous artistic contribution to debates in a society that is confronted with growing threats—real or perceived—from terrorism and cybercrime, surveillance and data misuse. It also inscribes itself into current Swiss political debates on Swiss arms exports and citizen privacy.

## EINE LANDSCHAFT AUS BILDERN UND DATEN

Dabei sind jedoch zwei Einschränkungen zu machen: Erstens kann (und will) das Projekt nicht von sich behaupten, dass es eine vollständige Studie aller Bestandteile des Schweizer Sicherheitskomplexes ist – Auslassungen waren notwendig. Das Projekt befasst sich weder mit der Justiz noch mit dem Strafvollzug. Andere Lücken – wie jene im Bereich der Geheimdienste oder Atomkraftwerke – sind die Folge fehlender Erlaubnis zu fotografieren. Zweitens ist das Projekt nicht als eine rein fotografisch-künstlerische Arbeit gedacht. Als Forschungsprojekt wird es von einem Buch begleitet, das die Fotografie mit verschiedenen Textformen und Datenvisualisierung kombiniert. Und auch die Ausstellung geht weit über die «reine» Präsentation von Fotoarbeiten hinaus. So entsteht in der Fotostiftung Schweiz eine komplexe Informationsumgebung, die von den Besuchern mit unterschiedlichen Sinnen erfahrbar ist, bestehend aus Karten, Statistiken und Grafiken, einer interaktiven, Sensor-modulierten Audio-Installation sowie einer Video-Installation mit zwei Projektionen an Decke und Boden. Ferner wird präsentiert, wie sich ein Cyberangriff auf einen infizierten Rechner auswirkt. Durch die Einbindung mehrerer «Forschungstische» in den Ausstellungsparcours werden Onlinequellen wie Filmmaterial sowie Druckerzeugnisse zugänglich gemacht, die einen tiefergehenden Einblick in das Thema gewähren.

Ungewöhnlich für eine Fotoausstellung ist auch, dass keine der Fotografien an einer Wand präsentiert wird, sondern auf eigens dafür hergestellten, im Raum verteilten Metallkonstruktionen. So entsteht ein narrativer Parcours, auf dem man die thematischen Kapitel als Cluster physisch erkunden und sinnlich erfahren kann. Sowohl die Gestaltung der Ständer, auf denen die Fotografien gezeigt werden, als auch das allgemeine Informationsdesign sind unter anderem inspiriert von der Ästhetik kommerzieller Sicherheitsmessen und wissenschaftlicher Bedienungsanleitungen im Bestreben, sich deren visuelle Register anzueignen und sie ins Bewusstsein zu heben. Das Projekt versucht somit Sprach- und Bildpolitiken aufzudecken, wie sie im Kraftfeld des transnationalen Sicherheitssystems verwendet werden. Dieser Ansatz steht im Einklang mit Salvatore Vitales beklemmender Bildsprache: Vorrangig ist nicht ein investigativer Ansatz mit dem Ziel der Entlarvung, sondern das Bemühen, schwer fassbare gesellschaftliche Befindlichkeiten sowie die strukturelle Gewalt des Systems spürbar zu machen.

Die Ausstellung ist dementsprechend als multiperspektivischer Denkraum und Aggregator konzipiert und erscheint als ein Wald aus Zeichen, eine urbane Landschaft

aus fotografischen Bildern, eine selektive «Grand Tour» des Schweizer Sicherheitssystems, das man in globaler Hinsicht als Inbegriff nationaler und transnationaler Sicherheitssysteme betrachten kann. Sie fokussiert auf einige der relevantesten gesellschaftspolitischen und technologischen Themen unserer Zeit.

Die Fotostiftung Schweiz präsentiert die erste umfassende Ausstellung dieses Werkkomplexes.

## BIOGRAFIE DES KÜNSTLERS

Salvatore Vitale (geb. 1986 in Palermo, Italien) ist ein in der Schweiz lebender Künstler und Publizist. Masterstudium der Bildenden Kunst an der Zürcher Hochschule der Künste (ZHdK). 2015–2016 erhielt er ein Pro Helvetia Nachwuchsförderungs-Stipendium und 2017 das PHmuseum-Award-Stipendium. 2018 wurden ihm ein Swiss Design Award, der FOAM Talent Award und der Punctum Award verliehen. Seine Werke sind in Museen und bei Foto-Festivals ausgestellt worden: u.a. im Photoforum Pasquart Biel, OCAT Shanghai und Shenzhen, MOCAP – Museum für Gegenwartskunst Krakau, Triennale der Photographie Hamburg, T3 Photo Festival Tokio und Jaipur International Photography Festival. Er lehrt an der Hochschule Luzern (HSLU) und hat weltweit Workshops geleitet. Salvatore Vitale ist darüber hinaus Mitbegründer und Chefredakteur von «YET», einer in der Schweiz erscheinenden internationalen, der zeitgenössischen Fotografie gewidmeten Zeitschrift.

## AN ARTISTIC APPROACH FROM THE INSIDE

In "How to Secure a Country" Vitale and his collaborators reflect and visualize the production of security (and therefore also insecurity) in photographs, texts, and data visualizations. The result aims at grasping the wider contexts and the functioning of an exemplary contemporary society that is in many ways emblematic of social, political and economic vectors and trends globally. Seen in this perspective Switzerland is part of globalization processes—as a localized node and point of culmination of many globalized flows and movements, but not based on a theory of historical exceptionalism.

According to Max Houghton's review in the online magazine 1000 Words, in Vitale's project: "A question hovers, and remains ever-present: when does a threat become a risk?". In order to research this and other questions with the goal to give insight into the internal system logic, collaboration with various specialists and researchers of the field was essential in, "[...] trying to assess one of the most complex security systems in the world and in gaining permission to access places otherwise sequestered."

A double disclaimer is potentially necessary here: First, of course, the project cannot claim to be an exhaustive study of all the elements of the Swiss security complex and this necessitated decisions of omission. For example, the project does not look at judicial institutions and processes nor at those of criminal correction. Other omissions, like those of the secret services or of nuclear power plants, are based on the lack of access and permissions to photograph.

Secondly, the project is not intended to be a purely photographic or artistic body of work. It is a visual research project that as a publication relies on the book's unique potential to combine photography, different forms of text and data visualization as part of a layout and a sequence. And the installation of the exhibition goes far beyond "just" presenting photographic works on walls.

## AFTER AND BEYOND PHOTOGRAPHY

Instead, it uses the open-plan space of the Fotostiftung Schweiz in order to generate a complex informational environment to be experienced with multiple senses by the visitors, as they manoeuvre a flexible itinerary activating the above components in different configurations and media. As alluded to above, multiple registers and layers of other visual material make up important parts of the exhibition's display strategy.

These consist of an interactive sensor-modulated audio installation, a two-screen video installation on ceiling and floor, text elements, maps, statistics, graphs, and digital data visualizations. This is complemented by an installation presenting the impact of a virus-based cyber attack on an infected virtual machine.

By integrating several research-tables into the exhibition itinerary, it also taps into online resources such as film footage and printed matter used as instructional and/or promotional material by the security system, in order to allow for further research and deeper insights into the topic.

## A LANDSCAPE OF IMAGES AND A FOREST OF SIGNS

The exhibition, then, is organized to be experienced as a forest of signs, an urban landscape of photographic images, a selective "grand tour" of the Swiss security system, which can be seen to be the epitome of national and transnational securitization strategies globally.

Unusually for a photographic exhibition, none of the images are presented on the walls but on custom-designed metal structures distributed in the space to create an itinerary to physically explore and sensorially experience the cluster based narratives, as well as the networks of cross-references contained in the information design elements on the walls.

The design of both the stands holding the photographs, as well as the general information design, take certain cues and logic from the worlds of commercial security fairs, but also from scientific visualization and instruction manuals. Yet it wasn't conceived as a one-to-one mimicry strategy. Although the somewhat ironic usage of the "How to"-element in the title is very present, the project's intention is certainly not to provide a utilitarian form of case study to be applied to other "cases". Rather it is used to reveal maybe even to sometimes unmask linguistic registers used by public and private actors in the force field that is the transnational security system.

The work focuses on some of the pressing and relevant socio-political, aesthetic and technological issues of our time. It was conceived as a think-tank or aggregator for the structuring of the complex field of the Swiss security complex, addressing various levels of popular culture, politics of representation and current societal discussions of security, privacy and risk management, and technology.

Fotostiftung Schweiz presents the first comprehensive exhibition of this body of work.



## SONDERVERANSTALTUNGEN

- Sonntag, 31. März, 11.30 Uhr  
Dialogische Führung  
Der Schweizer Sicherheitskomplex im globalen visuellen und politischen Kontext. Roland Bleiker (Professor für Internationale Beziehungen an der Universität Queensland) und Jonas Hagmann (Senior Researcher und Senior Lecturer am Institute of Science, Technology and Policy der ETH Zürich) im Gespräch mit Lars Willumeit.
- Sonntag, 21. April, 11.30 Uhr  
Künstlerführung  
Seeing the State vs. Seeing Like a State. Salvatore Vitale im Gespräch mit Lars Willumeit (in englischer Sprache).
- Sonntag, 12. Mai, 11.30 Uhr  
Podiumsgespräch  
Tracing Security in Late Modernity: From Investigative Processes to Media Exploration. Susan Schuppli (Künstlerin und Forscherin, Reader und Director am Centre for Research Architecture, Goldsmiths) im Gespräch mit Salvatore Vitale and Lars Willumeit (in englischer Sprache).
- Sonntag, 19. Mai, 11 Uhr  
Performance-Vortrag  
What, How and for Whom? Data Collection in the Name of Security. Mit Sicherheitsfachleuten und Datenexperten, organisiert von Opendata.ch (in englischer Sprache).

## PUBLIKATION

Bei Lars Müller Publishers erscheint die Publikation:  
How to Secure a Country. From Border Policing via Weather Forecast to Social Engineering—a Visual Study of 21st Century Statehood.

Herausgegeben von Salvatore Vitale und Lars Willumeit.

In Zusammenarbeit mit Fotostiftung Schweiz, Winterthur. Mit Essays von Roland Bleiker, Jonas Hagmann, Philip Di Salvo und Lars Willumeit.

In englischer Sprache. Design: Offshore Studio (Isabel Seiffert & Christoph Miler). 280 Seiten, 192 Illustrationen, Hardcover.





## ARTIST BIOGRAPHY

Salvatore Vitale (b. 1986, Palermo, Italy) is a Swiss-based visual artist and editor. Master of Fine Arts at the Zurich University of Arts (ZHdK). He was a recipient of the Swiss Arts Council grant in 2015-2016, the PHmuseum Award Grant in 2017, the Swiss Design Awards, FOAM Talent and Punctum Award in 2018. His work has been shown in museums and at photo festivals including the Photoforum Pasquart Biel/Bienne, OCAT Shanghai and Shenzhen, MOCAK—Museum of Contemporary Art Krakow, Hamburg Triennale of Photography, T3 Photo Festival Tokyo, and Jaipur International Photography Festival. He teaches at the Lucerne University of Applied Sciences and Arts (HSLU) and he has led workshops worldwide. Vitale is also the co-founder and editor-in-chief of YET magazine, a Swiss-based international photography magazine that focuses on the evolution of photography practice within the contemporary art field.

## SPECIAL EVENTS

- Sunday, 31 March, 11.30 a.m.  
Dialogical tour  
Der Schweizer Sicherheitskomplex  
im globalen visuellen und politischen Kontext. Roland Bleiker (Professor of International Relations at the University of Queensland) and Jonas Hagmann (Senior Researcher and Senior Lecturer at the Institute of Science, Technology and Policy at ETH Zurich) in conversation with Lars Willumeit (in German language).
- Sunday, 21 April, 11.30 a.m.  
Artist tour  
Seeing the State vs. Seeing Like a State. Salvatore Vitale in conversation with Lars Willumeit.
- Sunday, 12 May, 11.30 a.m.  
Panel discussion  
Tracing Security in Late Modernity: From Investigative Processes to Media Exploration. Susan Schuppli (artist and researcher, reader and director at the Centre for Research Architecture, Goldsmiths) in conversation with Salvatore Vitale and Lars Willumeit.
- Sunday, 19 May, 11 a.m.  
Performance lecture  
What, How and for Whom? Data Collection in the Name of Security. With security and data experts, organized by Opendata.ch.

## PUBLICATION

Lars Müller Publishers will be publishing the following book:  
How to Secure a Country. From Border Policing via Weather Forecast to Social Engineering—a Visual Study of 21st Century Statehood.

Edited by Salvatore Vitale and Lars Willumeit. In collaboration with Fotostiftung Schweiz, Winterthur. With essays by Roland Bleiker, Jonas Hagmann, Philip Di Salvo, and Lars Willumeit.

English language. Design: Offshore Studio. 280 pages, 192 illustrations, hardcover.

# Abschnitt Section

01  
01



Eine typische Schweizer Alpenlandschaft, eines der bekanntesten Bildgenres der Schweiz. Die Schweizer Alpen sind bis heute eine wichtige Verteidigungslinie und wurden von alters her als geologische Festung genutzt. 1880 entwickelte die Schweizer Regierung das Réduit-Dispositiv, einen Verteidigungsplan, der eine Reihe weit verteilter Befestigungen auf einer Ost-West-Linie durch die Alpen umfasst, um den zentralen Teil des Landes zu sichern. Spuren des Plans sind auch heute noch sichtbar, in Gestalt verborgener Bunker oder Waffen.

..... Nufenenpass, Wallis, 2017

A landscape of the Swiss Alps, one of Switzerland's most iconic image genres. The Swiss Alps have long represented one of the country's first lines of defense, and they have historically been used as a geological fortification. In 1880 the government developed the Swiss National Redoubt or Réduit, a defensive plan encompassing a widely distributed set of fortifications on a general east-west line through the Alps to secure the central part of Switzerland. Traces of the plan still linger, and such a landscape can hide concealed bunkers or weapons.

..... Nufenen Pass, Valais, 2017



Leuchtschrift einer Schweizer Zollstelle in Grenznähe zu Italien. Das Grenzschutzkorps (GWK) ist der bewaffnete und uniformierte Teil der Zollbehörden und bildet die grösste nationale zivile Sicherheitsbehörde der Schweiz.

..... Ponte Tresa, 2015

Neon sign on top of a Swiss customs post at the Swiss-Italian border. The Border Guard (BG) is the armed and uniformed corps of the Federal Customs Administration (FCA). The BG is the largest national civil security body in Switzerland.

..... Ponte Tresa, 2015



Ein Schild an einem abgelegenen Zollübergang, das den Beginn des Schweizer Territoriums markiert. Die Aufrechterhaltung von entlegenen Grenzübergängen ist Teil einer laufenden Diskussion über deren wirtschaftliche und sicherheitspolitische Bedeutung zwischen Schweizer Behörden und Politikern.

..... Schweizer Grenze, Brusino Arsizio, 2016

A traffic sign to mark the beginning of Swiss territory at a remote customs post. The protection of remote customs posts is part of an ongoing discussion between Swiss authorities and politicians about the economic and public security fields.

..... Swiss Border, Brusino Arsizio, 2016



Monitore mit Bildern von Überwachungskameras, die überall an der Schweizer Grenze platziert sind. Auf Weisung des schweizerischen Grenzschutzkorps (GWK) wurden die Bilder aus Sicherheitsgründen unkenntlich gemacht.

..... Schweizer Grenze, Ponte Tresa, 2016

Monitors showing images from security cameras placed all over the Swiss border. The images were censored for security reasons upon request of the Swiss Border Guard.

..... Swiss Border, Ponte Tresa, 2016

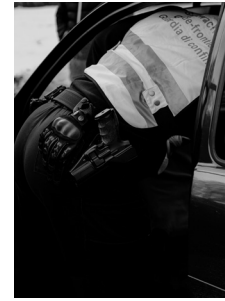

Ein Mitarbeiter des Grenzschutzkorps (GWK) während einer Sicherheitskontrolle. Kontinuierlich durchgeführt, zielt diese Art der Kontrolle darauf ab, illegale Aktivitäten wie Schmuggel von Waren, Geldwäsche, illegale Einwanderung und Drogenimport zu identifizieren und zu stoppen.

..... Schweizer Grenze, Zollstelle Fornasette, 2015

A Border Guard agent during a security check. This type of control is very frequent and aims to identify and stop illegal activities such as the smuggling of goods, contraband, money laundering, illegal immigration and drug importing.

..... Swiss Border, Fornasette Customs, 2015



Ein Schild in eritreischer Sprache, das besagt: «Hier sind wir in der Schweiz». Die Grenzschutzbeamten bringen diese Schilder in den Grenzschutzposten an, da viele Migrant/innen keine Kenntnis davon haben, dass sie eine Grenze überschreiten, und einige auch nichts von der Existenz der Schweiz wissen. Viele sind lediglich ihrer Muttersprache mächtig.

..... Chiasso, 2015

A sign written in Eritrean language at the border saying: "Here we are in Switzerland". Border guards put these signs all over the customs post as the migrants in many cases are not aware of the fact that they are crossing a border, with some unaware even of the existence of Switzerland, and often speaking only their mother tongue.

..... Chiasso, 2015



Höhenmessskala in einem Grenzschutzposten.

..... Schweizer Grenze, 2015

Height measurement scale in a cell inside of a customs post.

..... Swiss Border, 2015



Die Eidgenössische Zollverwaltung (EZV), bestehend aus Zoll und Grenzwachtkorps (GWK), deckt mehrere Aufgabenbereiche ab und ist dem Eidgenössischen Finanzdepartement angegliedert. Dazu gehört die Erhebung von Steuern und Abgaben wie Mehrwertsteuer, Zölle und Strassenverkehrsabgaben.

..... Schweizer Grenze, Ponte Tresa, 2015

The Federal Customs Administration (FCA), consisting of the The Border Guard (BG) and Swiss Customs, cover several areas of responsibility. Among these is the levying of taxes and duties such as value added tax, customs duties, and road traffic duties.

..... Swiss Border, Ponte Tresa, 2015



Sicherheitszelle in einem Grenzwachtposten. Das Grenzwachtkorps verfügt über Auffangräume für den Fall der Sicherungsverwahrung. Alle Objekte in der Zelle sind so befestigt und gesichert, dass sie nicht als Waffe gegen sich selbst oder andere verwendet werden können.

..... Schweizer Grenze, Ponte Tresa, 2015

Security cell in a customs post at the border. Customs posts are provided with rooms utilized for cases of preventive detention. All of the objects inside the cell are fastened and secured so as to avoid their use as a weapon in case of riots or suicide attempts.

..... Swiss Border, Ponte Tresa, 2015



Ein Grenzwachtkorpsbeamter führt bei einer Einwanderungskontrolle am Bahnhof an der schweizerisch-italienischen Grenze eine Fingerabdruckerfassung durch. In diesem speziellen Fall kontrolliert die Grenzpolizei einen eritreischen Asylbewerber. 2016 haben 27 207 Personen in der Schweiz Asyl beantragt. Die wichtigsten Herkunftsländer waren Eritrea, Afghanistan, Syrien, Somalia, Sri Lanka und Irak.

..... Schweizer Grenze, Chiasso, 2016

A border guard is performing a fingerprint registration during an immigration control at the railway station at the Swiss-Italian border. In this particular case the Border Police controls an Eritrean asylum seeker. In 2016, 27,207 persons applied for asylum in Switzerland. The main countries of origin were Eritrea, Afghanistan, Syria, Somalia, Sri Lanka and Iraq.

..... Swiss Border, Chiasso, 2016

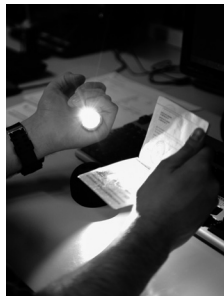

Passkontrolle an einem Schweizer Grenzübergang. Die Schweiz beteiligt sich als Teil des Schengen-Raums am Projekt «Smart Borders», das mit modernster Technologie die Effizienz der Grenzkontrollen an den Schengen-Aussengrenzen erhöht und die Sicherheit im Innern verbessert. Im Mittelpunkt dieses Projekts steht das elektronische Entry/Exit-System EES.

..... Schweizer Grenze, Chiasso, 2015

Passport control at a Swiss customs post. As a part of the Schengen Area, Switzerland is taking part in the project "Smart Borders" which uses state-of-the-art technology to increase the efficiency of border controls at Schengen external borders and improve security within the Schengen area. Central to this project is the electronic Entry/Exit System (EES).

..... Swiss Border, Chiasso, 2015

## Abschnitt Section

02  
02



Ein Sturmgewehr, das für das Sportschiessen modifiziert wurde. Die militärfreundliche Haltung vieler Schweizer/innen hat das Zielschiessen auch bei Kindern zu einem beliebten Nationalsport gemacht.

..... Origlio, Tessin, 2015

An assault rifle customized for sports purposes. The Swiss pro-military culture has made target shooting a popular national sport, even amongst children.

..... Origlio, Ticino, 2015



Die Schweiz verfügt weltweit über die zweitgrössten Streitkräfte pro Kopf der Bevölkerung. Der Militärdienst ist obligatorisch, wobei fast alle in Frage kommenden Männer eine Ausbildung zum Soldaten absolvieren und Frauen als Freiwillige dienen können. Die Schweizer Armee verteidigt das Land und sein Volk gegen einen militärischen Angriff. Sie unterstützt die zivilen Behörden bei der Bewältigung von Naturkatastrophen und bei der Bekämpfung ernsthafter Bedrohungen der inneren Sicherheit. Sie bietet auch Hilfe im Rahmen der internationalen Friedensunterstützung und der humanitären Hilfe an.

..... Bern, 2017

Switzerland has the second largest armed force per head of population in the world. Military service is mandatory with almost all eligible males trained as soldiers and also women serve as volunteers. The Swiss Armed Forces defend the country and its people against a military attack. They support the civilian authorities in dealing with natural disasters and in countering serious threats to internal security. They also offer assistance within the context of international peace support and humanitarian aid.

..... Bern, 2017

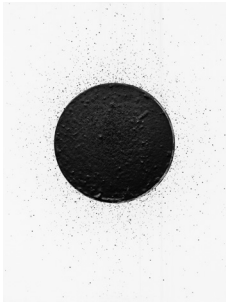

Ein militärisches Trainingsziel, das auch häufig für das Sportschiessen verwendet wird.

..... Origlio, 2015

An official military training target, which is also commonly used for sport target shooting.

..... Origlio, 2015



Zeremonie der Protokollabteilung des Verteidigungsministeriums. Diese Sektion der Schweizer Armee befasst sich mit allen protokollarischen und zeremoniellen Angelegenheiten des Bundesrats, des Bundespräsidenten und des Vorstehers des Eidgenössischen Departements für auswärtige Angelegenheiten. Sie organisiert offizielle Besuche und verwaltet die Vorrechte und Immunitäten des diplomatischen Corps. In diesem Fall besuchte der Chef der polnischen Armee den Chef der Schweizer Armee anlässlich eines diplomatischen Treffens und einer Gedenkfeier.

..... Bern, 2016

Ceremony of the Protocol Section part of the Defence Ministry. This section of the Swiss Army deals with all protocol and ceremonial matters concerning the Federal Council, the president of the Confederation and the head of the Federal Department of Foreign Affairs. It organizes official visits and manages privileges and immunities of the diplomatic corps. In this particular case the chief of the Polish Army visited the chief of the Swiss Army for a diplomatic meeting and a commemoration.

..... Bern, 2016

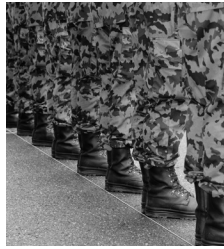

Zeremonie der Protokollabteilung des Verteidigungsministeriums.

..... Bern, 2016

Ceremony of the Protocol Section part of the Defence Ministry.

..... Bern, 2016



Die Schweizer Armee organisierte die Simulation eines Terroranschlags in Grenznähe zu Italien. An der Operation mit dem Namen «ODESCALCHI» waren viele der Behörden und weitere Akteure beteiligt, die an der Herstellung von Sicherheit in der Schweiz mitwirken.

..... Chiasso, 2017

The Swiss Army organized a simulation-exercise of a terrorist attack at the Italian-Swiss border. The operation, called "ODESCALCHI", involved many of the agencies and actors producing security in Switzerland.

..... Chiasso, 2017



Ein Truppenübungsplatz in der Region Solothurn. Diese Art von multifunktionaler Struktur wird verwendet, um die Soldaten auf verschiedene Arten von Bedrohungen vorzubereiten. Solche Strukturen werden auch als Bildhintergründe bei der Herstellung von Werbemitteln eingesetzt. Die Schweizer Armee arbeitet aktiv mit anderen Institutionen zusammen. So wird dieser Übungsplatz auch von Forschenden im Bereich Robotik der ETH Zürich genutzt, um ihre Entwicklungen zu testen.

..... Übungsdorf Wangen a. A., Solothurn, 2018

A military training camp in the region of Solothurn. This kind of multifunctional structure is used to train the soldiers to face several kinds of threat. Structures like this are also used for the production of promotional materials. The Swiss Army actively collaborates with other institutions: for example, this training camp is also used by

the Robotics department of the University of Zurich in order to test their machines.

..... Übungsdorf Wangen a. A., Solothurn, 2018



Das Innere eines Super Pumas der Schweizer Luftwaffe. Dieser Hubschrauber wird für Verbindungs-, Rettungs- und Katastropheneinsätze verwendet.

..... Mendrisio, 2016

The interior of a Swiss Air Force Super Puma Helicopter used for liaison, rescue and disaster relief.

..... Mendrisio, 2016

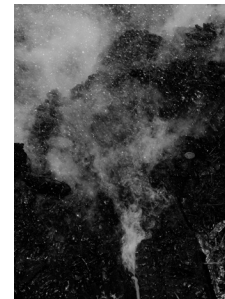

Ein kontrollierter Brand während der Simulation eines Terroranschlags in Grenznähe zu Italien.

..... Chiasso, 2016

A controlled blaze during a simulation of a terrorist attack at the Italian-Swiss border.

..... Chiasso, 2016



Ansicht eines Sanitätszelts während der Operation «ODESCALCHI», der Simulation eines Terroranschlags in Grenznähe zu Italien, an der viele der Institutionen und Akteure beteiligt waren, die für die Sicherheit im Land sorgen.

..... Chiasso, 2016

View of a medical camp staged during the operation "ODESCALCHI", a simulation-exercise of a terrorist attack at the Italian-Swiss border involving many of the institutions and actors producing security in the country.

..... Chiasso, 2016

# Abschnitt Section

03  
03



Diensthund der Hundeeinheit auf der Suche nach Drogen während einer Polizeiaktion im Kanton Zürich.

..... Zürich, 2016

Canine unit's dog looking for drugs during a police operation in the Canton Zurich.

..... Zurich, 2016



Kontrollraum der kantonalen Polizeieinsatzleitung Zürich zur Überwachung der Autobahnen in der Region Zürich. Das Schweizer Schnellstrassensystem ist eine zentrale Achse für den Waren- und Personenverkehr in Europa.

..... Zürich, 2016

Control room of the Zurich Cantonal Police operation centre for monitoring highways in the Zurich region. The Swiss highway system provides a central route within Europe for the circulation of goods and people.

..... Zurich, 2016



Munition, die mit dem SIG SG 550, dem Schweizer Sturmgewehr (auch Sturmgewehr 90 genannt) verwendet wird.

..... Origgio, 2015

Bullets used with the SIG SG 550, the Swiss Assault Rifle.

..... Origgio, 2015

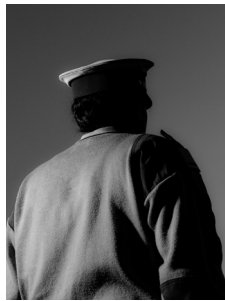

Private Sicherheitsbeamtin. Die private Sicherheit ist ein integraler Bestandteil des schweizerischen Sicherheitssystems. Die Armee delegiert verschiedene Dienstleistungen an private Sicherheitsunternehmen, und die Schweizer Regierung unterstützt die Regulierungsbemühungen für private Militär- und Sicherheitsunternehmen (PMSCs). So trägt sie zwei Multi-Stakeholder-Initiativen mit, um Regierungs- und Unternehmensvertreter für Standards zu gewinnen, die PMSCs regulieren. Der Montreux-Prozess ist eine rein zwischenstaatliche Initiative; er zielt darauf ab, die Staaten zur Einhaltung des humanitären Völkerrechts und der Menschenrechte zu verpflichten, wenn sie private Sicherheitsdienstleister einsetzen.

..... Lugano, 2018

Private security agent. Private security is an integral part of the Swiss security system. Swiss military forces often delegate various services to private security companies and the Swiss government is a principal supporter of regulatory efforts for private military and security companies (PMSCs). It sponsors two multi-stakeholder initiatives aimed at gaining government and company signatories to standards which govern PMSCs. The Montreux process is a purely intergovernmental initiative; it seeks to commit states to upholding international humanitarian law and human rights if and when they use private security contractors.

..... Lugano, 2018

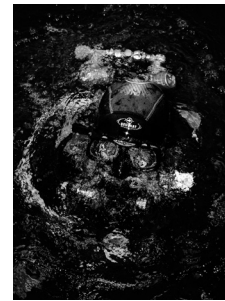

Seepolizistin auf Patrouille während eines Rettungseinsatzes im Zürichsee. Die Abteilung Seepolizei der Kantonspolizei Zürich mit Sitz in Oberrieden am Zürichsee ist Teil der Verkehrspolizei. Sie überwacht den Verkehr auf dem Wasser und wird auch schweizweit für schwierige Tauch-, Such- und Rettungsaktionen eingesetzt.

..... Zürich, 2016

Lake police agent going on a patrol during a rescue mission in the Lake of Zurich. The Seepolizei Department of the Zurich Cantonal police, based in Oberrieden on Lake Zurich, is part of the traffic police. It monitors traffic on the water and is also used throughout Switzerland for difficult diving, search and rescue operations.

..... Zurich, 2016

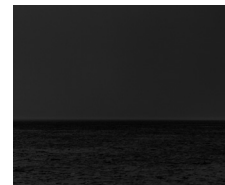

Ein heftiger Sturm am Luganersee, der von MeteoSchweiz als «Stufe 4-Sturm» (steht für grosse Gefahr) klassifiziert wurde. Seit fast 140 Jahren spielt MeteoSchweiz, der nationale Wetter- und Klimadienst der Schweiz, eine wichtige Rolle für die Sicherheit und den Wohlstand des Landes. Seine Mission ist es, der Schweizer und internationalen Öffentlichkeit zuverlässige Wetter- und Klimadienstleistungen zu bieten.

..... Lugano, 2018

A violent storm on the lake of Lugano classified as Level 4 (meaning a major level of danger) by MeteoSwiss. For almost 140 years, MeteoSwiss, the Swiss national weather and climate service, has been playing an important role in the country's safety and prosperity. Their mission is to provide reliable weather and climate services for the Swiss public and the international community.

..... Lugano, 2018



Fotografische Reinterpretation und Aneignung der Betriebsanleitung des Schweizer Sturmgewehrs SIG SG 550. Die Schweiz liegt bei der Anzahl der Waffen pro Kopf nur hinter den USA und dem Jemen; auf 100 Personen kommen rund 29 Waffen, und jeder vierte Haushalt hat eine Waffe. Schweizer Soldaten lagern ihre persönliche Waffe zu Hause; es steht ihnen frei, sie nach dem Austritt aus der Armee zu behalten.

..... 2015

Photographic re-interpretation and re-appropriation of the instruction manual of the SIG SG 550, the Swiss Assault Rifle. Switzerland is behind only the US and Yemen in the number of guns per capita; there are around 29 guns for every 100 people, and one in four households has a gun. Swiss soldiers store their personal weapons at home and they are offered to keep them once they leave the army.

..... 2015



Fotografische Reinterpretation und Aneignung der Betriebsanleitung des Schweizer Sturmgewehrs SIG SG 550.

..... 2015

Photographic re-interpretation and re-appropriation of the instruction manual of the SIG SG 550, the Swiss Assault Rifle.

..... 2015

## Abschnitt Section

04  
04



Ein typisches Schweizer Chalet, das einen Militärbunker verbirgt.

..... Nufenenpass, Wallis, 2017

A typical Swiss chalet which hides a military bunker.

..... Nufenen Pass, Valais, 2017



Deltalis, das angeblich sicherste Rechenzentrum der Schweiz, verbirgt sich tief im Innern eines Bergs. Es befindet sich in einem ehemaligen Militärbunker. Diese Art von Infrastruktur eignet sich hervorragend für den Bau eines Rechenzentrums, da sie bereits mit einer autonomen Energie- und Wasserversorgung ausgestattet ist. Das Kühlsystem arbeitet mit zwei separaten, redundanten Wasserspeichern. Verschiedenen Quellen zufolge hat das Deltalis-Rechenzentrum Ende 2018 seine Geschäftstätigkeit eingestellt. Die Zukunft der Infrastruktur ist noch unklar.

..... Attinghausen, Eielen Fort DK2 0, 2018

DELTALIS, the safest Datacenter deep inside a Swiss Mountain. This data center is built inside a former military bunker. This type of infrastructure is perfect for the construction of a data center as, among others like it, it is already equipped with autonomous power and water supplies. DELTALIS' cooling operates with two separate, redundant water reservoirs used as a primary cooling circuit. According to various sources, DELTALIS ceased operation at the end of 2018. The future of the infrastructure still remains unclear.

..... Attinghausen, Eielen Fort DK2 0, 2018



Ein gebrauchsfertiger Bunker, in dem die Bevölkerung im Fall eines Angriffs untergebracht werden könnte. Einzigartig ist, dass die Schweiz über genügend Schutzbunker verfügt, um die gesamte Bevölkerung aufzunehmen. 2006 gab es 300 000 Unterkünfte in privaten Wohnhäusern, Institutionen und Spitälern sowie 5100 öffentliche Unterkünfte, die insgesamt 8,6 Millionen Menschen Schutz bieten – eine Abdeckung von 114 Prozent.

..... Vacallo, 2017

A ready-to-use bunker to host the population in case of attack. Switzerland is unique in having enough nuclear fallout shelters to accommodate its entire population. In 2006, there were 300,000 shelters in Swiss dwellings, institutions and hospitals, as well as 5,100 public shelters, providing protection for a total of 8.6 million individuals—a coverage of 114 per cent.

..... Vacallo, 2017



Detailaufnahme einer Ruinenlandschaft, entstanden als Ergebnis eines Brandes während einer simulierten Rettungsaktion.

..... Chiasso, 2016

A detail from a rescue mission under some ruins generated by a blaze as a result of a simulation.

..... Chiasso, 2016



Ein Detail der Aussenwände einer Struktur, die aus Beton besteht. Ihre unregelmäßige Form soll das Rechenzentrum vor elektromagnetischen Angriffen schützen. Diese Art von Angriff gehört zu den gefährlichsten für ein Rechenzentrum.

..... Attinghausen, Eielen Fort DK2 0, 2018

Close-up of the external walls of a structure which is made of concrete. The irregular shapes are designed to protect the data center from electromagnetic attacks. These kinds of attacks are among the most dangerous and critical for a data center.

..... Attinghausen, Eielen Fort DK2 0, 2018



Das Vision for Robotics Lab (V4RL) an der Eidgenössischen Technischen Hochschule Zürich (ETH) untersucht die Zusammenarbeit verschiedener Roboter. Durch die Analyse des Bildstroms und aller Sensordaten soll ein zeitnahes und umfassendes Verständnis der Umgebung erreicht werden, um die Navigation und Interaktion der Roboter mit ihrer Umgebung zu automatisieren. Kleine unbemannte Luftfahrzeuge (UAVs) gehören zu den agilsten und anspruchsvollsten Systemen, auf die sich das Labor spezialisiert. Diese Luftfahrzeuge können in Gruppen zusammenarbeiten und sind so in der Lage, autonom Such- und Rettungseinsätze durchzuführen, wobei sie intuitive und benutzerfreundliche Schnittstellen für den menschlichen Piloten bieten.

..... Übungsdorf Wangen a. A., Solothurn, 2018

The Vision for Robotics Lab (V4RL) at the Swiss Federal Institute of Technology in Zurich (ETH) is studying the collaboration among different robots. Analyzing the image stream and all sensor cues as they are being captured, they aim to achieve a timely and rich enough understanding of the robots' surroundings in order to provide them with the information necessary to automate their navigation and their interaction with their environment. As some of the most agile and challenging platforms, the lab has a focus on small Unmanned Aerial Vehicles (UAVs). These Aerial Vehicles can form a novel aerial robotic team that possesses the capability to autonomously conduct search and rescue missions, while additionally providing intuitive and user-friendly interfaces to human operators.

..... Übungsdorf Wangen a. A., Solothurn, 2018



Das Vision for Robotics Lab (V4RL) an der Eidgenössischen Technischen Hochschule Zürich (ETH) untersucht die Zusammenarbeit verschiedener Roboter.

..... Zürich, 2018

The Vision for Robotics Lab (V4RL) at the Swiss Federal Institute of Technology in Zurich (ETH) is studying the collaboration among different robots.

..... Zurich, 2018

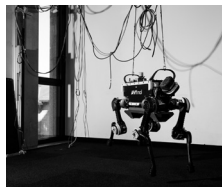

Das Robotic Systems Lab an der Eidgenössischen Technischen Hochschule Zürich (ETH) hat ANYmal entwickelt: einen vierfüssigen Roboter für den autonomen Betrieb in anspruchsvoller Umgebung. Angetrieben von adaptiven und das Drehmoment präzise regelnden Stellgliedern ist das System in der Lage, dynamisch zu laufen und hochmobil zu klettern. Dank der integrierten Lasersensoren und Kameras kann der Roboter seine Umgebung wahrnehmen, um kontinuierlich Karten zu erstellen und sich präzise zu lokalisieren. Basierend auf diesen Informationen kann er seinen Navigationspfad autonom planen und beim Gehen sorgfältig Fuss fassen.

..... Zürich, 2018

The Robotic Systems Lab at the Swiss Federal Institute of Technology in Zurich (ETH) has developed ANYmal: a quadrupedal robot designed for autonomous operation in challenging environments. Driven by special compliant and precisely torque controllable actuators, the system is capable of dynamic running and high-mobile climbing. Thanks to incorporated laser sensors and cameras, the robot can perceive its environment to continuously create maps and accurately localize. Based on this information, it can autonomously plan its navigation path and carefully select footholds while walking.

..... Zurich, 2018



ANYmal, ein vierfüssiger Roboter für den autonomen Betrieb in anspruchsvoller Umgebung. Er ist in der Lage, Such- und Rettungseinsätze durchzuführen, hier während eines Trainingstages auf einem Truppenübungsplatz.

..... Übungsdorf Wangen a. A., Solothurn, 2018

ANYmal, a quadrupedal robot designed for autonomous operation in challenging environments. It is able to perform search and rescue missions as shown here, during a training day on a military training field.

..... Übungsdorf Wangen a. A., Solothurn, 2018

# Abschnitt Section

05  
05

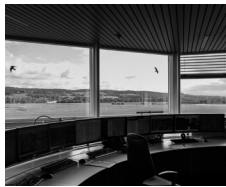

Wetterbeobachtungsstation am Flughafen Zürich. Alle 30 Minuten wird von MeteoSchweiz-Mitarbeitenden ein Wetterbericht für den Flughafen erstellt.

..... Flughafen Zürich, 2018

Weather observation station at the airport of Zurich. Every 30 minutes a weather report for the airport is performed by MeteoSwiss employees.

..... Zurich Airport, 2017

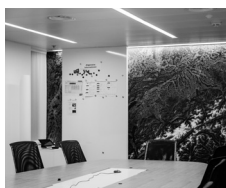

Der Operations Room von MeteoSchweiz dient zur Bewältigung von Ausnahmesituationen.

..... Flughafen Zürich, 2017

The MeteoSwiss operations room is used in case of a business contingency.

..... Zurich Airport, 2017



Die Flugwetter-Prognostiker am Flughafen Zürich verwenden eine Sichtbarkeitsskala, um die aktuelle Sichtweite zu ermitteln. Dies geschieht durch visuelle Beobachtung (und andere Hilfsmittel) von verschiedenen Geländepunkten auf der Horizontlinie, wodurch die Entfernung vom Beobachtungszentrum am Flughafen bestimmt werden kann. Die Sichtweite wird wie folgt eingestuft:  $\geq 8$  km = Oscar = Offen;  $8$  km  $\geq 5$  km = Delta = Schwierig;  $5$  km  $\geq 2$  km = Mike = Kritisch;  $< 2$  km = X-ray = Geschlossen.

..... Flughafen Zürich, 2017

The aviation forecasters at the airport of Zurich use a visibility scale in order to determine the current visual range. This is done by using different regional locations on the horizon line, in order to determine, through visual observations and other tools, the distance from the observation centre at the airport. They categorize the visual range as follows:  $\geq 8$  km = Oscar = Open;  $8$  km  $\geq 5$  km = Delta = Difficult;  $5$  km  $\geq 2$  km = Mike = Marginal;  $< 2$  km = X-ray = Closed.

..... Zurich Airport, 2017



Das Centro Svizzero di Calcolo Scientifico (CSCS) entwickelt und betreibt Hochleistungscomputersysteme als unverzichtbare Serviceeinrichtung für Schweizer Forschende. Diese Computersysteme werden von Wissenschaftlern für unterschiedlichste Zwecke eingesetzt – von hochauflösenden Simulationen bis hin zur Analyse komplexer Daten. Das Zentrum wird von der ETH Zürich betrieben und befindet sich in Lugano.

..... Lugano, 2018

Swiss National Supercomputing Centre (CSCS) develops and operates cutting-edge high-performance computing systems as an essential service facility for Swiss researchers. These computing systems are used by scientists for a diverse range of purposes—from high-resolution simulations to the analysis of complex data. The Centre is operated by ETH Zurich and is located in Lugano.

..... Lugano, 2018



Detail eines People Pod, einer Arbeitsstation am Hauptsitz von Open Systems in Zürich. Seit 1990 konzentriert sich Open Systems auf Netzwerke und Sicherheit für globale Unternehmen, NGOs und Institutionen. Der Arbeitsplatz wurde gebaut, um einen visuellen Eindruck eines so schwer fassbaren und unsichtbaren Themas wie der Cybersicherheit zu vermitteln. 2010 wurden die Büros von Open Systems in Zürich als Gewinner des Wettbewerbs «World's Coolest Offices» mit einem Architizer A+ Award ausgezeichnet.

..... Open Systems AG, Zürich, 2017

Detail of People Pod, a working station at the Open Systems headquarter in Zurich, Switzerland. Since 1990, Open Systems fo-

cuses on networks and security for global enterprises, NGOs and institutions. The workplace has been built in order to give a visual glimpse of such an elusive and invisible topic as cyber security. In 2010, Open Systems' workplace in Zurich was a winner in the Inc. and Architizer magazine contest for the "World's Coolest Offices".

..... Open Systems AG, Zurich, 2017



Die neuen Büroräume am Hauptsitz von Open Systems in Zürich. Open Systems sichert und überwacht IT-Netzwerke und geschäftskritische Anwendungen für globale Unternehmen, NGOs und Institutionen. Das 1990 gegründete Unternehmen bietet hochgesicherte Netzwerke durch die vollständige Integration von SD-WAN (softwaredefinierte Vernetzung in einem Wide Area Network), Web- und Anwendungssicherheit sowie Incident-Handling- and-Response-Dienstleistungen. Open Systems ist derzeit in mehr als 180 Ländern tätig, mit Betriebszentren in Zürich und Sydney, Australien, und einem Büro in New York, USA.

..... Open Systems AG, Zürich, 2017

Open Systems' new offices at their Zurich headquarter. Open Systems secures and monitors IT networks and business-critical applications for global enterprises, NGOs and institutions. Founded in 1990, the company offers security enabled networks by fully integrating SD-WAN (software-defined networking in a wide area network), Network Security, Web and Application Security, as well as Incident Handling and Response. Open Systems currently operates in more than 180 countries, with operations centers in Zurich and Sydney, Australia, and an office in New York, USA.

..... Open Systems AG, Zurich, 2017



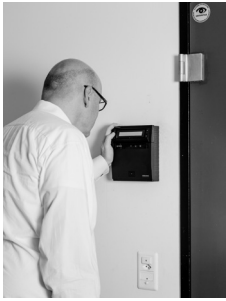

Ein Mitarbeiter von Open Systems bedient eine Sicherheitsschleuse. Alle Türen und Portale des Zugangs in den Gebäuden sind nur nach biometrischer Augenerkennung passierbar.

..... Open Systems AG, Zürich, 2017

An employee at Open Systems opening a door using a security gate. All doors and portals of access in the buildings are possible by biometric eye-recognition only.

..... Open Systems AG, Zurich, 2017



Ausschnitt aus dem «Disease Control and Prevention Work Safety Kit». Auf Anordnung von Florian Gutzwiller, der das Unternehmen Open Systems 1990 gegründet hat, muss jeder am Firmensitz in Zürich tätige Ingenieur seine persönlichen Arbeitsmittel einsetzen, um die Gefahr einer möglichen Ansteckung der Mitarbeitenden zu vermeiden.

..... Open Systems AG, Zürich, 2017

Detail of the "Disease control and prevention workplace safety kit". Following the vision of Florian Gutzwiller, who founded the company Open Systems in 1990, every engineer working at the company headquarter in Zurich has to use their personal working tools in order to avoid risks of possible contagion between employees.

..... Open Systems AG, Zurich, 2017



Supercomputer im Centro Svizzero di Calcolo Scientifico (CSCS). Die beiden Cray-CS-Storm-Schränke für modellbasierte Wetterprognosen von MeteoSchweiz tragen die Namen «Kesch» und «Es-cha», die auf Deutsch (Piz Kesch) und auf Romanisch (Piz d'Es-cha) nach einem Gipfel in den Albula-Alpen benannt sind. Mit 3418 Metern ist er der höchste Gipfel der Albula-Region Graubündens.

..... Lugano, 2017

Swiss National Supercomputing Centre (CSCS). The two Cray CS-Storm cabinets for MeteoSwiss' numerical weather predictions are named "Kesch" and "Escha" which are the names in German (Piz Kesch) and in Rumanch (Piz d'Escha) of a peak in the Albula region of the Rhaetian Alps in Switzerland. At 3,418 meters, it is the highest peak in the Albula Alps of Grisons.

..... Lugano, 2017



Supercomputer im Centro Svizzero di Calcolo Scientifico (CSCS).

..... Lugano, 2017

Supercomputer in the Swiss National Supercomputing Centre (CSCS).

..... Lugano, 2017



Detail der Benutzeroberfläche der Mission Control Security Services bei Open Systems. Architektur und Benutzeroberfläche wurden in Zusammenarbeit mit einem bildenden Künstler entwickelt, mit dem Ziel, einen unsichtbaren Dienst sichtbar zu machen und so den Kunden eine konkrete Vision und Materialität zu vermitteln.

..... Open v AG, Zürich, 2017

Detail of the Mission Control Security Services interface at Open Systems. The architecture and user interface of the Mission Control was developed in collaboration with a visual artist in order to render visible what is an invisible service, with the aim of providing clients with a concrete vision and materiality.

..... Open Systems AG, Zurich, 2017

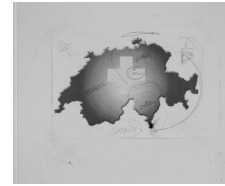

Ein Schild an der Schweizer Grenze, das die Position auf der Karte für Migranten veranschaulicht, die versuchen, das Land von Italien aus zu betreten. Die Grenzschutzbeamten haben diese Schilder innerhalb der Grenzwachststellen angebracht, da vielen Migranten nicht bewusst ist, dass sie eine Grenze überschreiten, und einige auch nichts von der Existenz der Schweiz wissen.

..... Chiasso, 2015

A sign at the Swiss border illustrating the position on the map to the migrants who try to cross the border coming from Italy. Border guards have put up these signs all over the customs post, as in many cases the migrants are not aware of the fact that they are crossing a border, with some even unaware of the existence of Switzerland as a country.

..... Chiasso, 2015

# THE SWISS SECURITY LANDSCAPE

## Which agents work on which threat?

### SWISS MINISTRIES AND AGENCIES

ABUND	Other federal public administration entities
ARMA	Federal Office for Defense Procurement
BABS	Federal Office for Civil Protection
BJ	Federal Office of Justice
CCPC	Conference of Cantonal Police Commanders of Romandie, Berne and Ticino
CCPD	Police and Customs Cooperation Centre
DEZA	Swiss Agency for Development and Cooperation
EDA	Federal Department of Foreign Affairs, State Secretariat
EJPD	Federal Department of Justice and Police
EZV	Civil Customs
FEDPOL	Federal Office of Police
GWK	Swiss Border Guard
KANTZ	Cantonal civil protection agencies
KAPO	Cantonal police forces
NDB	Federal Intelligence Service
OPOL	Police Concordat of Eastern Switzerland
PKNW	Police Concordat of North-Western Switzerland
PKOM	Parliamentary Defense Committees
POL	Cantonal and municipal police forces
SEM	State Secretariat for Migration
STGP	Municipal police forces
SVS	Swiss Security Network
VBS	Federal Department of Defense, Civil Protection and Sports
VBSGS	VBS secretary's office
VBSVT	Swiss Armed Forces
ZIVFE	Cantonal civil protection and fire brigades
ZPK	Police Concordat of Central Switzerland

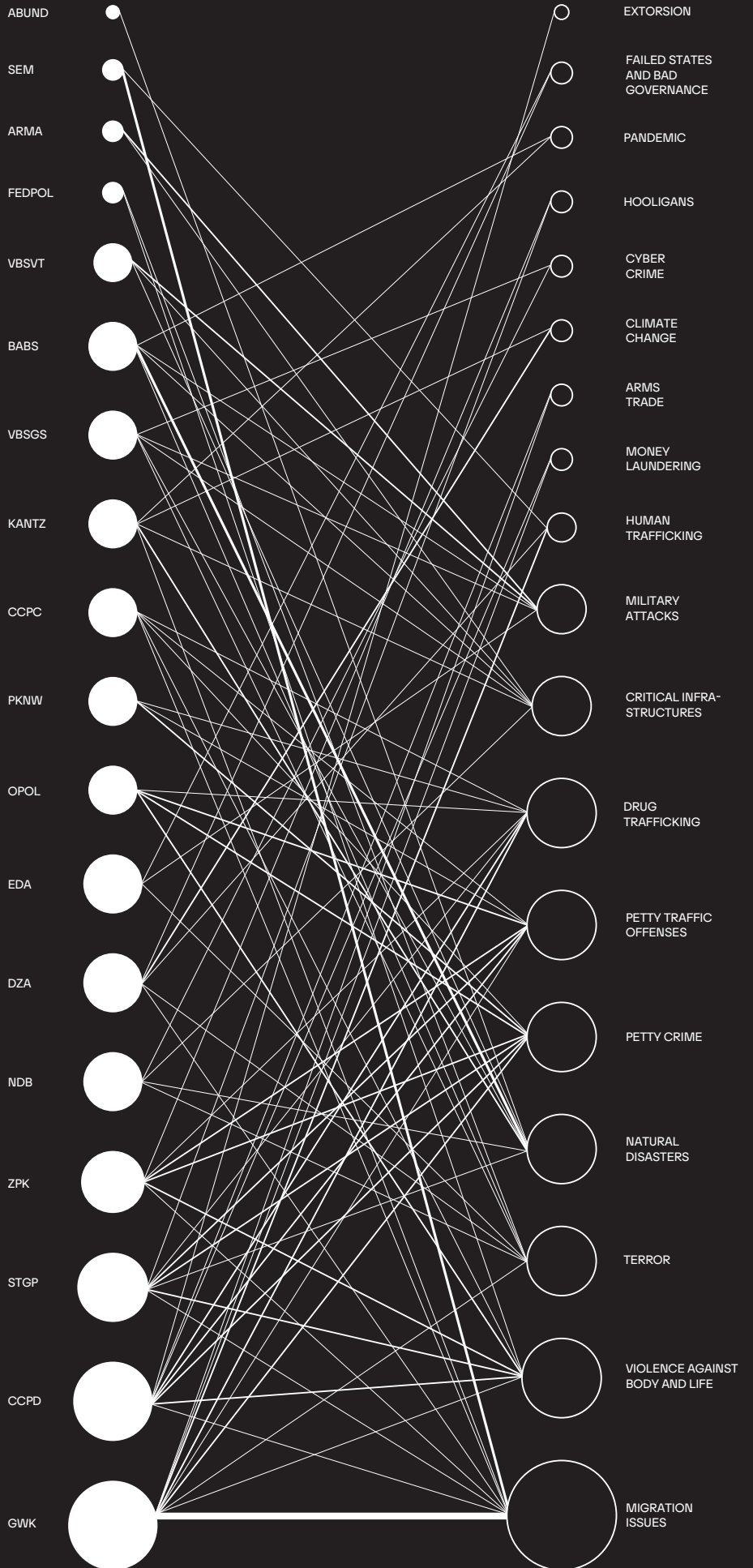

- Centrality (number of cooperations) of agents in the security field
- National and international cooperation partners / threats
- ≡ Intensity of relationship

# Which Swiss agents cooperate?

**SWISS MINISTRIES AND AGENCIES**

ABUND	Other federal public administration entities
ARMA	Federal Office for Defense Procurement
BABS	Federal Office for Civil Protection
BJ	Federal Office of Justice
CCPC	Conferece of Cantonal Police Commanders of Romandie, Berne and Ticino
CCPD	Police and Customs Cooperation Centre
DEZA	Swiss Agency for Development and Cooperation
EDA	Federal Department of Foreign Affairs, State Secretariat
EJPD	Federal Department of Justice and Police
EZV	Civil Customs
FEDPOL	Federal Office of Police
GWK	Swiss Border Guard
KANTZ	Cantonal civil protection agencies
KAPO	Cantonal police forces
NDB	Federal Intelligence Service
OPOL	Police Concordat of Eastern Switzerland
PKNW	Police Concordat of North-Western Switzerland
PKOM	Parliamentary Defense Committees
POL	Cantonal and municipal police forces
SEM	State Secretariat for Migration
STGP	Municipal police forces
SVS	Swiss Security Network
VBS	Federal Department of Defense, Civil Protection and Sports
VBSGS	VBS secretary's office
VBSVT	Swiss Armed Forces
ZIVFE	Cantonal civil protection and fire brigades
ZPK	Police Concordat of Central Switzerland

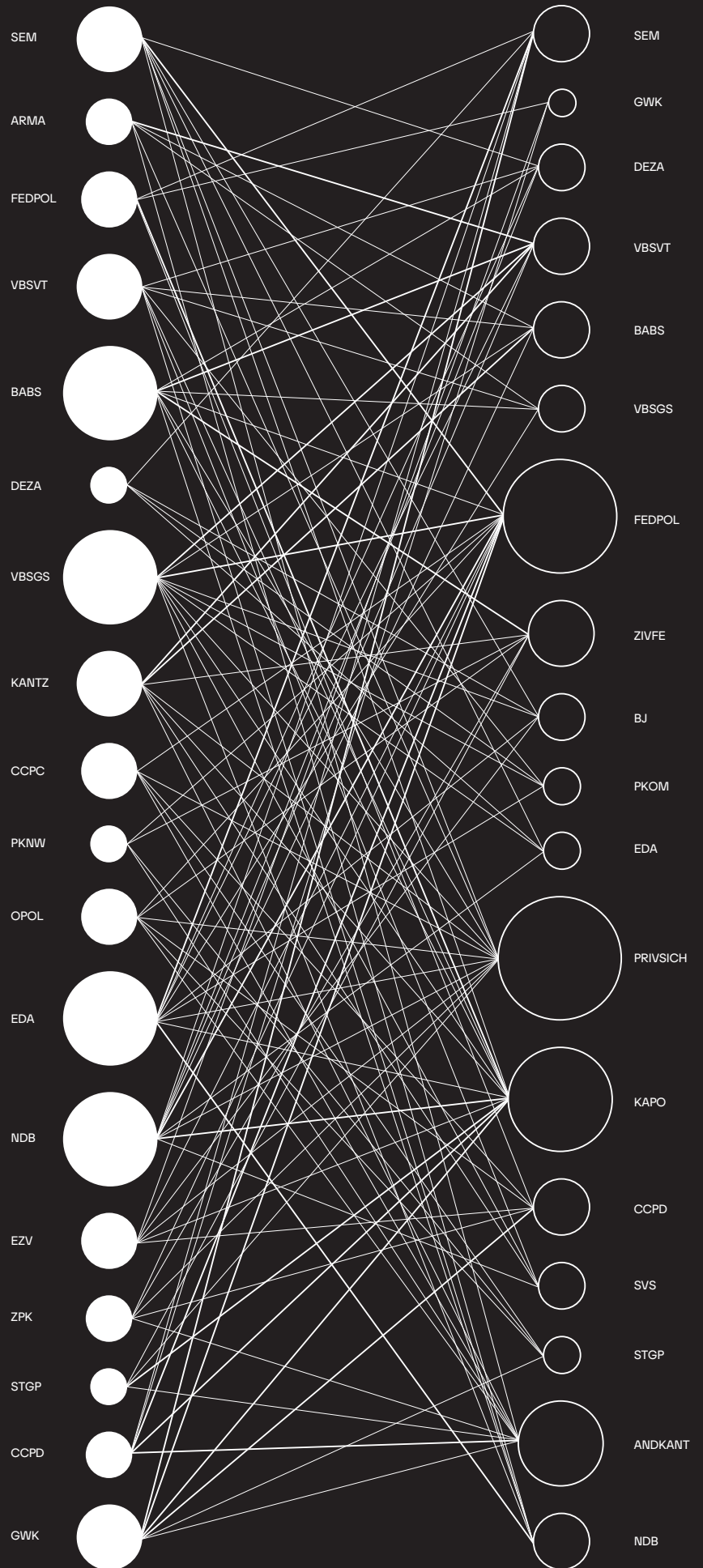

- Centrality (number of cooperations) of agents in the security field
- National and international cooperation partners / threats
- ≡ Intensity of relationship

# Which Swiss agents cooperate with which international partner?

## INTERNATIONAL PARTNERS

ARNN	Armed forces of further (non-neighboring) countries
ARN	Armed forces of neighboring countries
EVA	European Defense Agency
EUAPR	Euro-Atlantic Partnership Council
EUSAG	EU security agencies (e.g. Europol, Frontex, Olaf)
INTERP	Interpol
NATO	North Atlantic Treaty Organization
ND	Intelligence services
OSZE	Organization for Security and Cooperation in Europe
PFF	Partnership for Peace
POLEU	Police forces/agencies of further European countries
POLNA	Police forces/agencies of neighboring countries
PONEU	Police forces/agencies of extra-European countries
SPEZB	Specialists at foreign embassies in Switzerland
UNOAG	Specialized UN agencies
ZIV	Civil protection agencies
ZOLL	Customs and border guard agencies

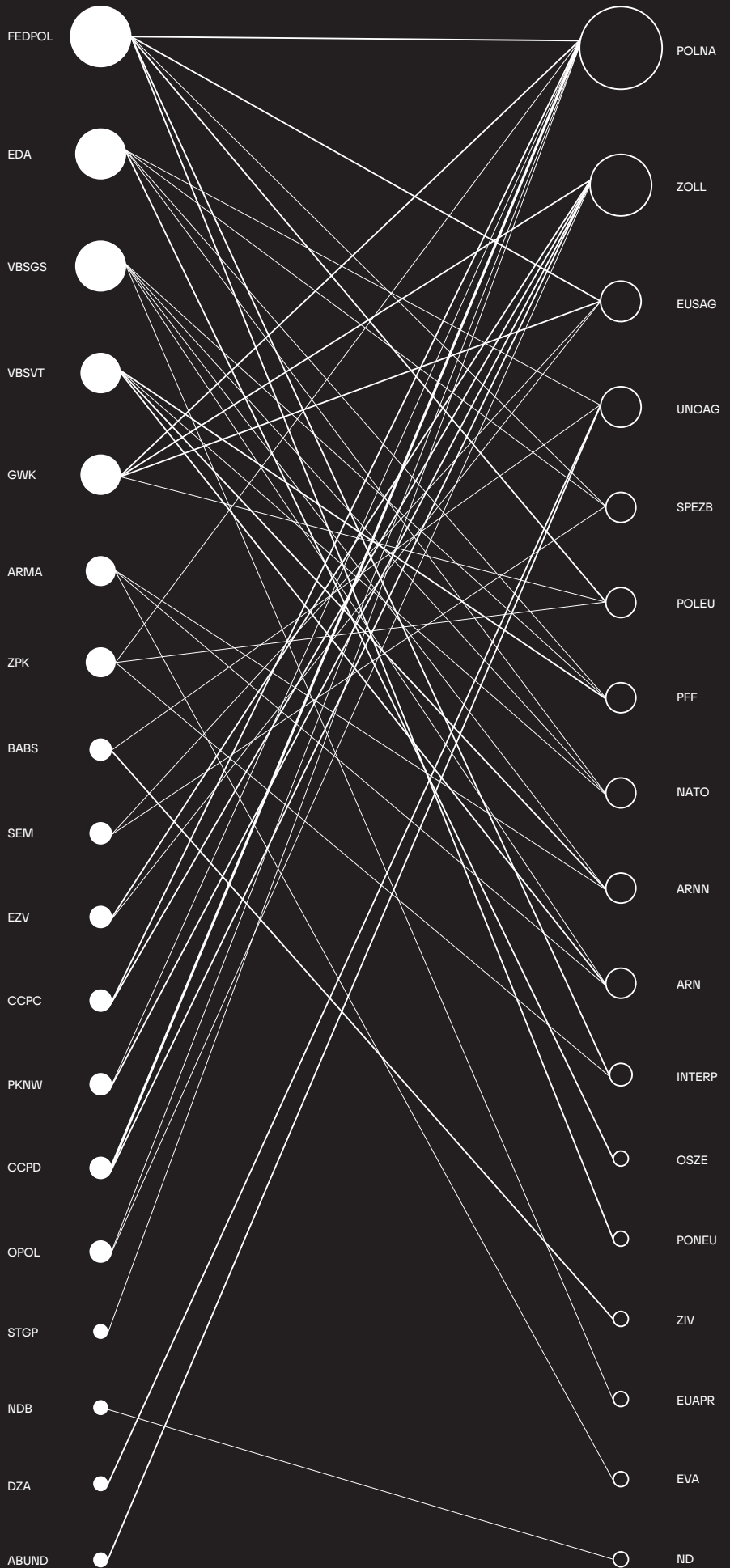

- Centrality (number of cooperations) of agents in the security field
- National and international cooperation partners / threats
- ≡ Intensity of relationship



# INTEGRATED BORDER MANAGEMENT

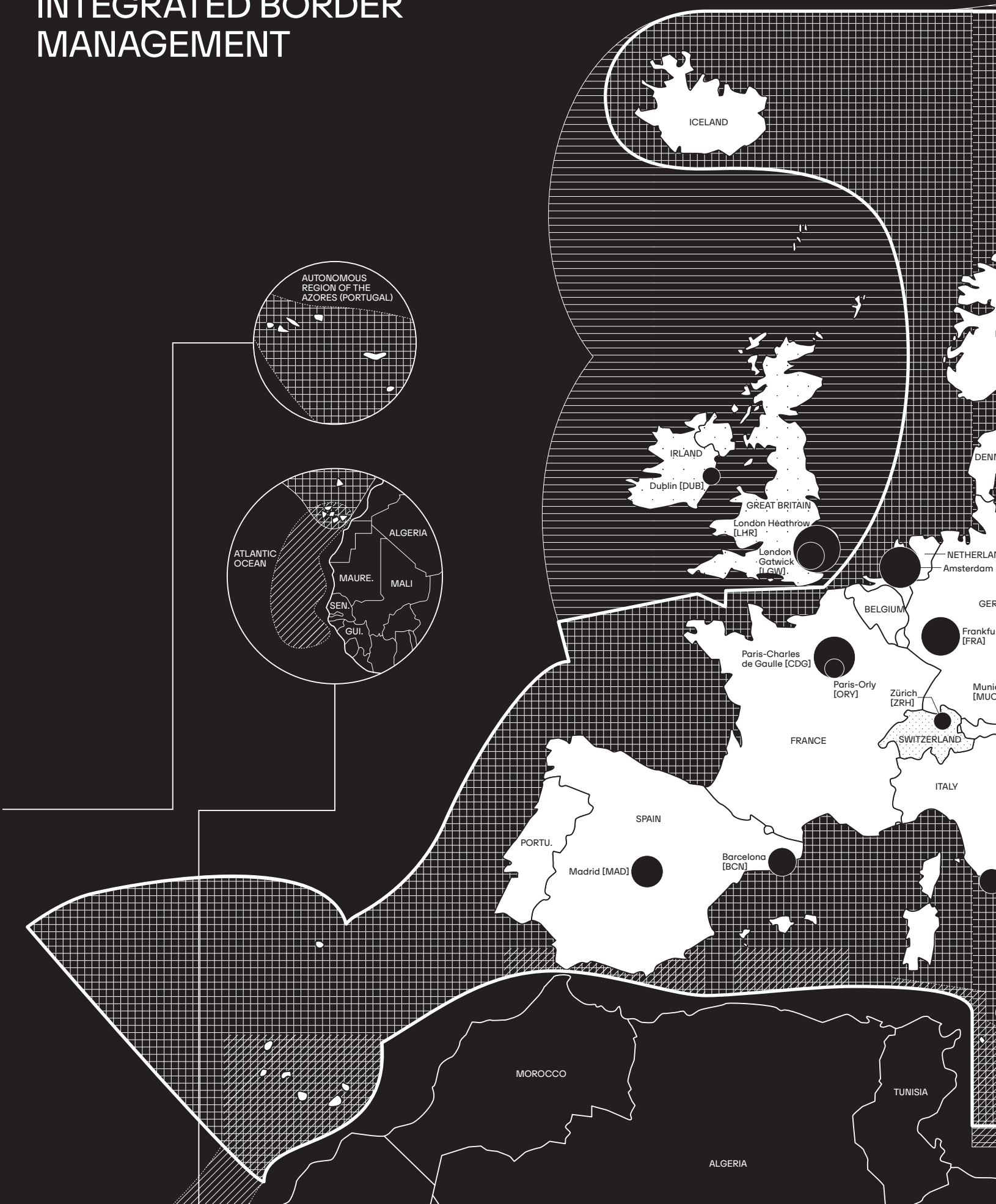

Since Switzerland joined the Schengen area in 2008, its border controls were abolished to guarantee free movement within Schengen. However, to keep abreast of the growing complexity of transnational migration and crime, Switzerland collaborates with the Schengen states to strengthen the external borders of the area in various ways.

 Schengen Area (42.673km sea border, 7.721km land borders and hundreds of airports)

 Schengen member states

 Common Travel Area (CTA)

 FRONTEX operational area

 Past and present FRONTEX operations

 Major border checkpoints

 Major European airports (>29 mio. passengers/year)

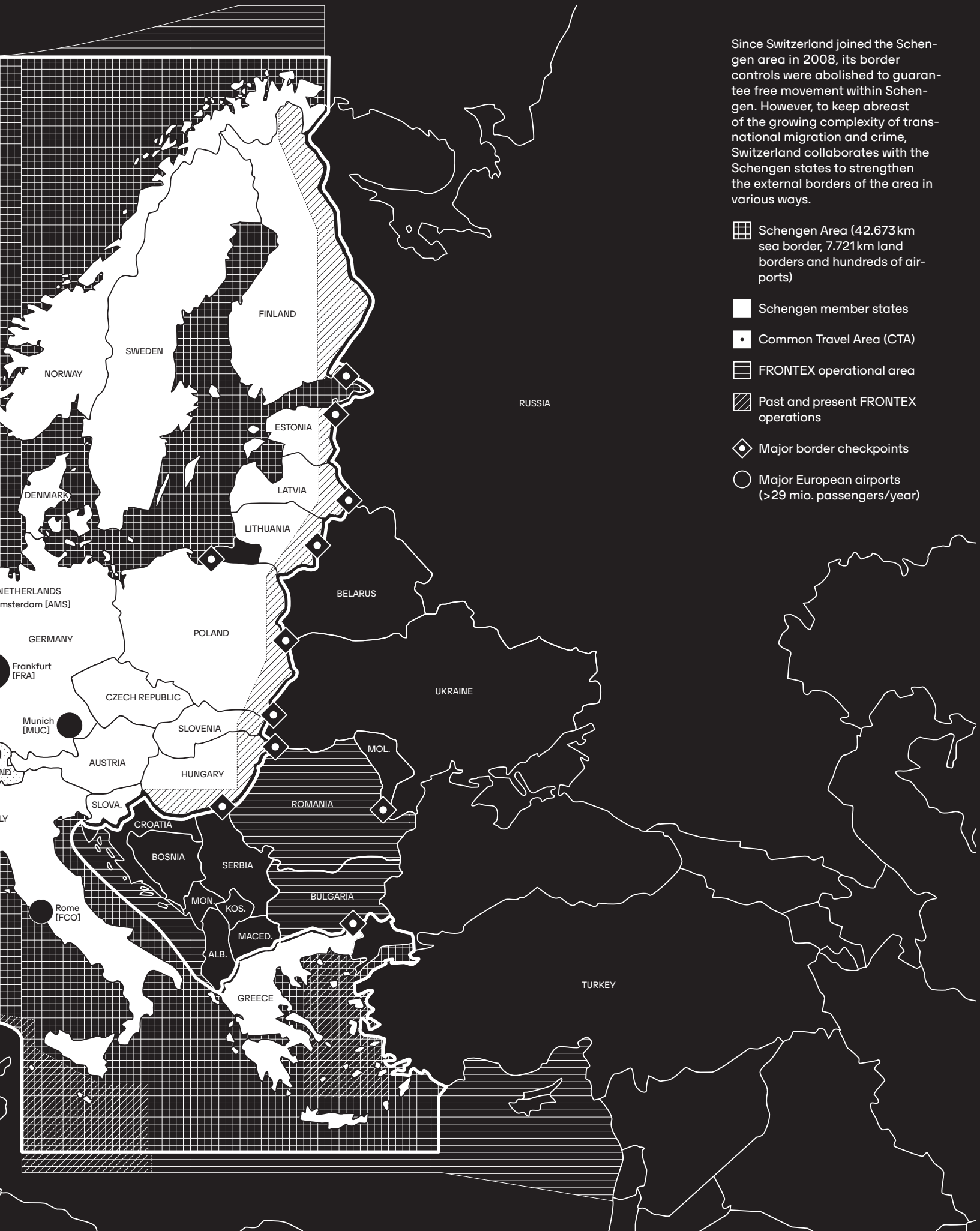

## FOUR-FILTER IMMIGRATION CONTROL MODEL

The actual extension of Switzerland's borders in the context of Schengen and the European external border strategies is realised through four 'filters'. This model assumes that measures to ensure efficient and successful prevention of illegal immigration should begin even before the Schengen external border, in the countries of origin or transit, and should also include measures within the Schengen Area.

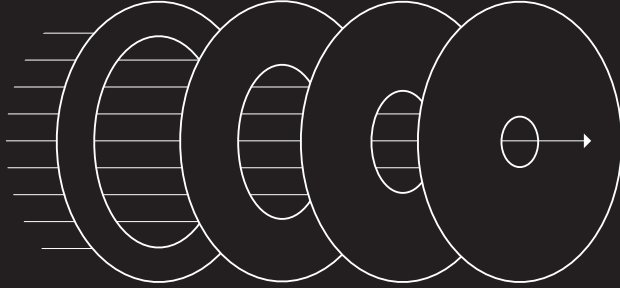

- 1 Actions in non-Schengen countries, e.g. visa procedures, use of Airline Liaison Officers who assist airlines in document control, cooperation with and sanctioning of airlines who carry passengers without documents
- 2 Cooperation within Schengen area, e.g. European Border and Coast Guard FRONTEX
- 3 Measures at external border control, e.g. passenger data verification and storage, automated border control of third-country residents by Entry-Exit-System (from 2020)
- 4 Measures within the territory, e.g. targeted internal controls or forgery detection

## BIOMETRIC DATA

In 2011 all Schengen members have introduced the Visa Information System (VIS), where biometric data (fingerprints and digital photograph) of the visa applicant is stored. The data is also shared with the Schengen Information System (SIS), which contains alerts on people who are wanted, missing or are banned from entry. The collection of biometric data is a joint decision of the Schengen countries to better protect applicants against identity theft and prevent false identifications.

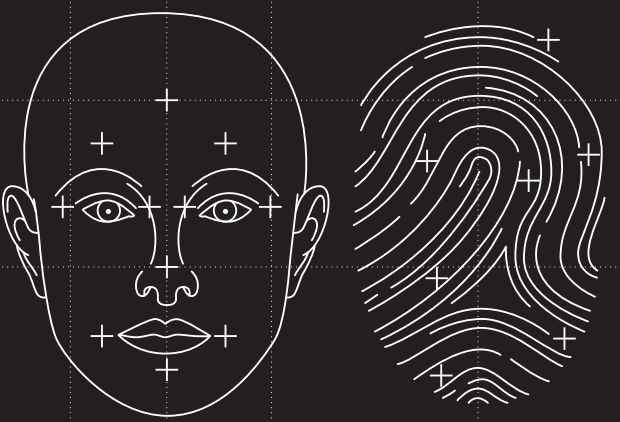

- 1+2 Biometric scanners record identities by plotting the unique geometry of a face or fingerprint on a grid

## TOP-10 NATIONS VISAS ISSUED (○2016 / ●2017)

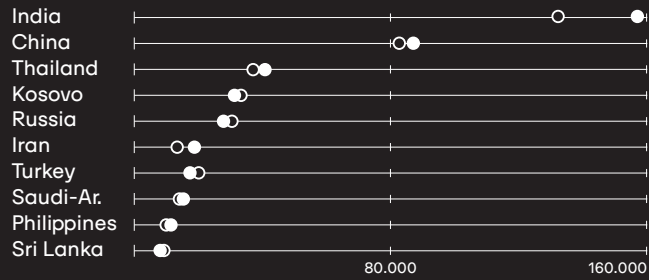

## TOP-10 NATIONS VISAS DENIED (○2016 / ●2017)

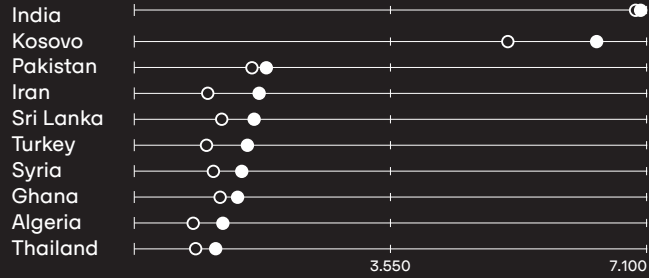

## SEX AND AGE OF VISA APPLICANTS (2017)

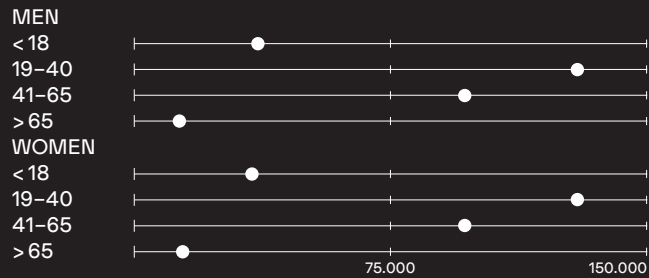

## TOP-10 EMBASSIES THAT ISSUED DIPLOMATIC OR SPECIAL PASSES (2017)

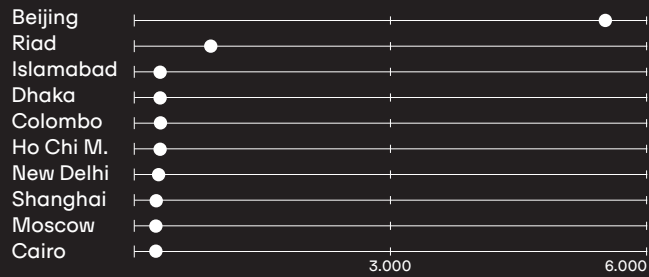





# THE SWISS ARMY: ITS MISSION AND STRATEGIES

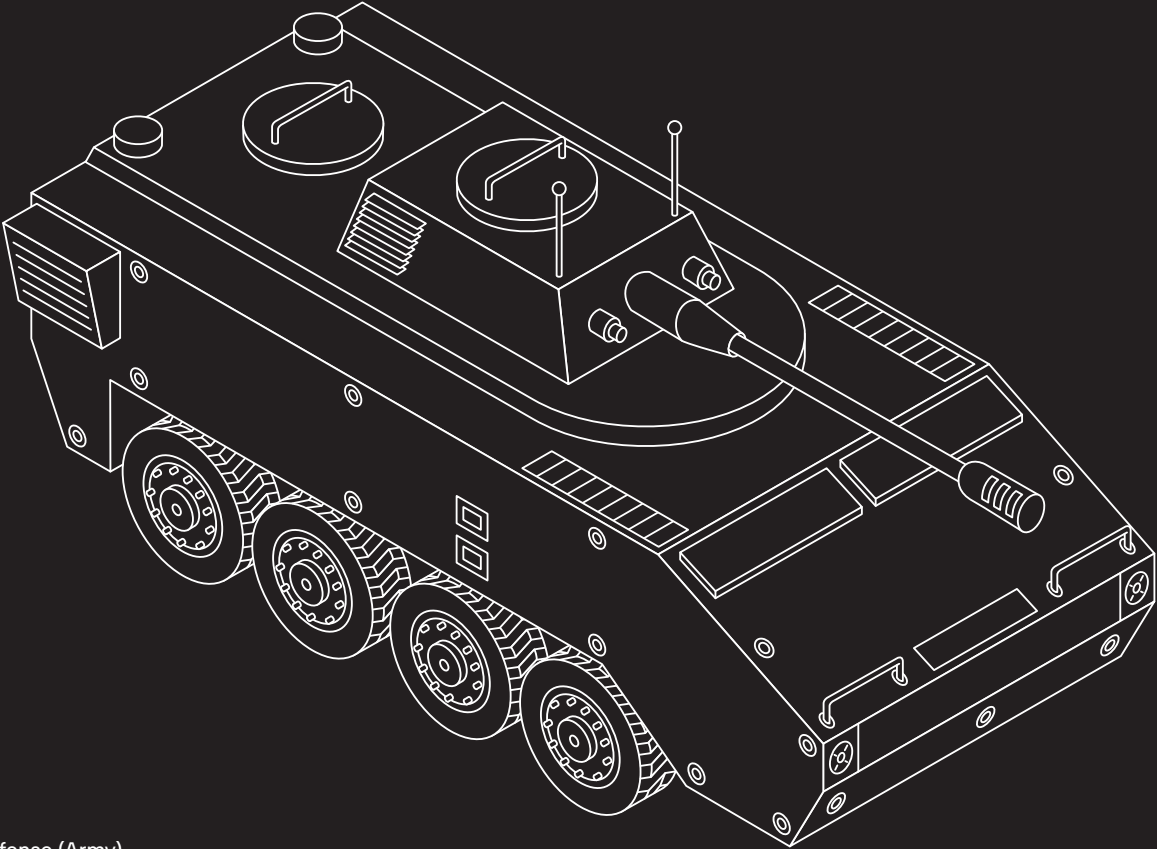

1 Ground defense (Army)

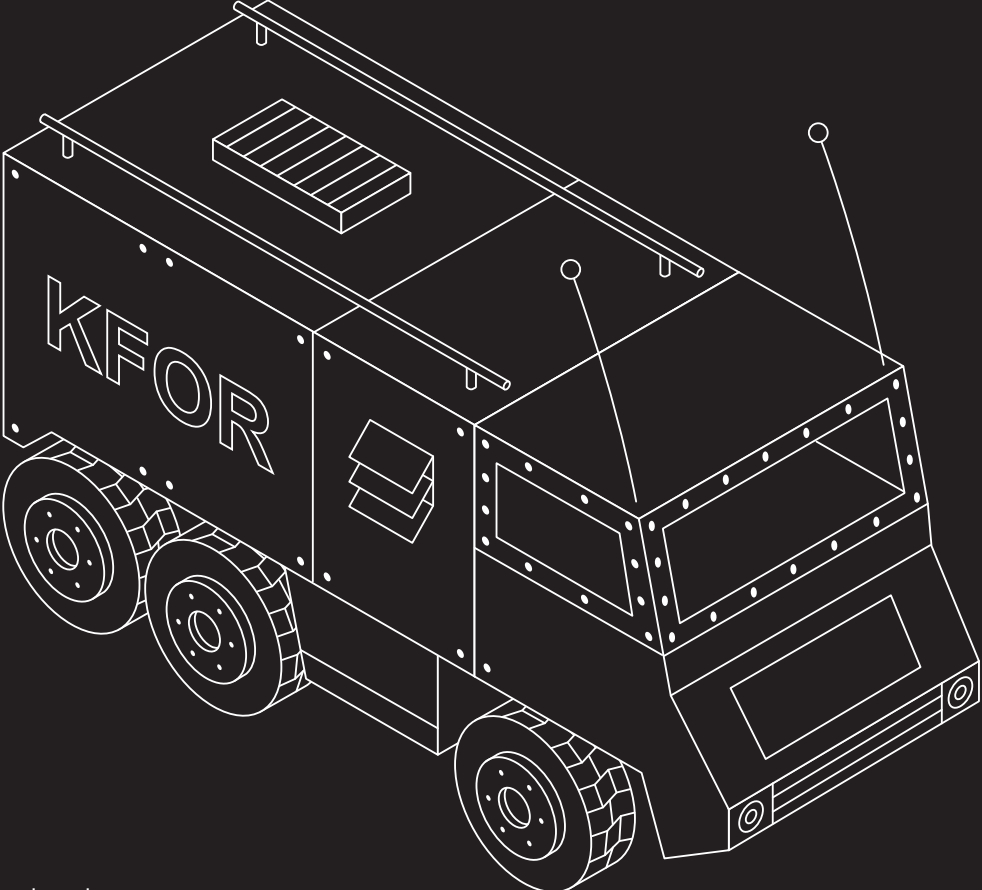

2 Promotion of peace abroad

The Swiss army's mission has shifted since the end of the Cold War. Its focus is less and less on the defense of the country and increasingly on managing the risks of complex threats within Switzerland. As a result, the size of the army has shrunk from 400,000 to about 180,000 members, whereas the annual budget is set to grow from 9 to 15 billion Swiss francs by 2030.

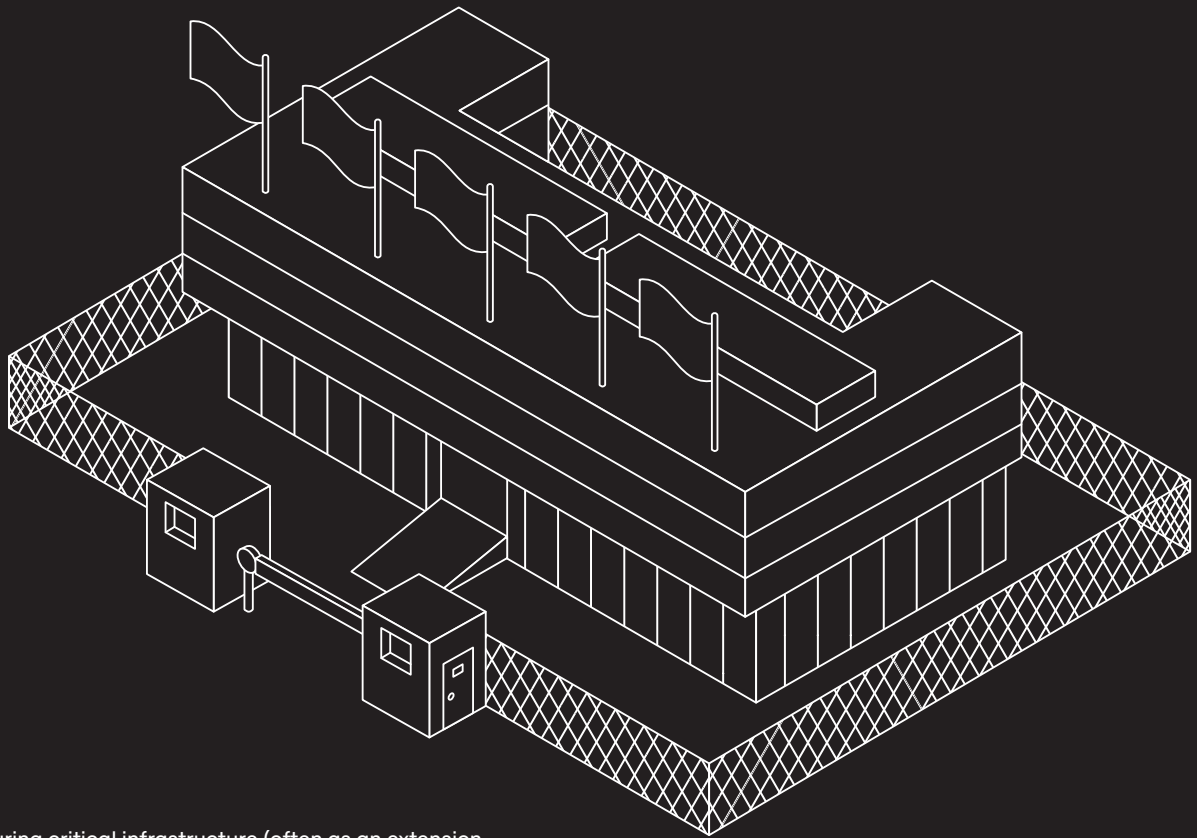

3 Securing critical infrastructure (often as an extension of the police, such as at WEF Davos)



4 Disaster relief

While a large majority of Swiss (81%) see the army as a necessity, 36% feel that Switzerland spends "far too much" on defense. Cost of selected military services per day (CHF): Pay-56.7 million, Meals-53.5 million, Housing-25.5 million, Transportation-44.7 million



5 Representation in accordance with protocol

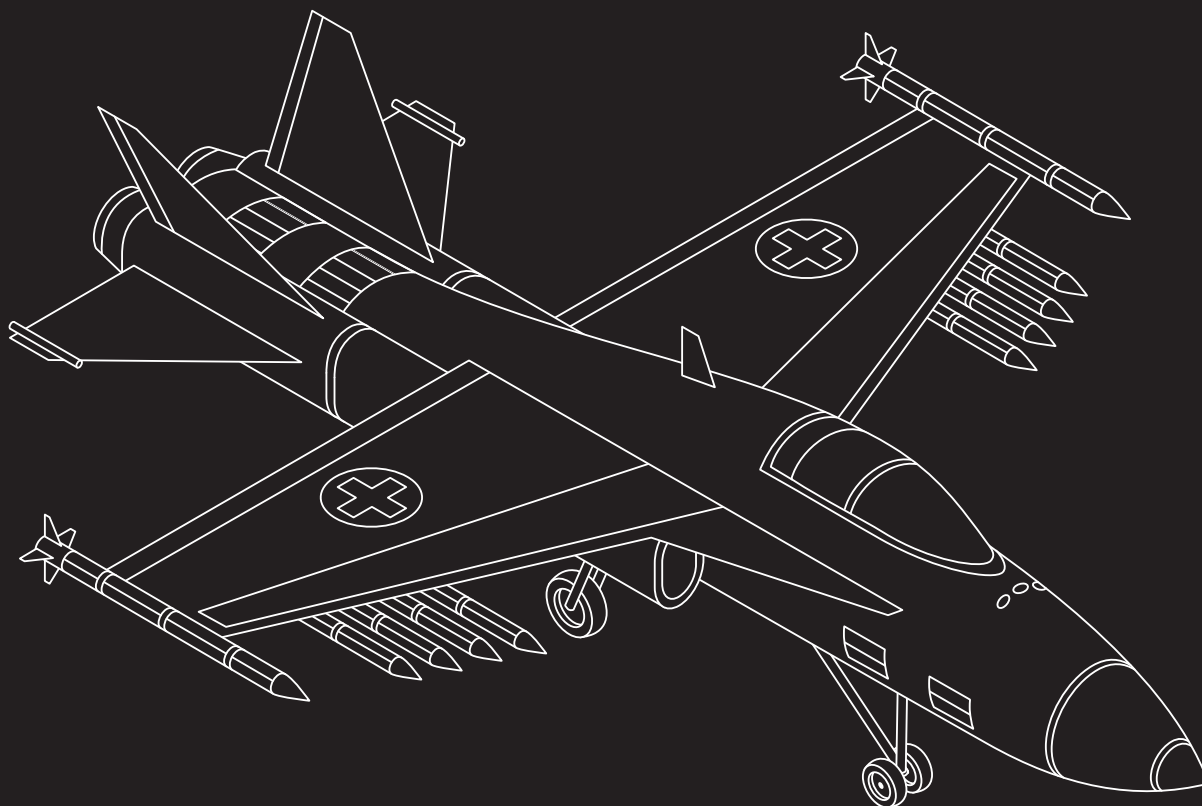

6 Air defense (Air Force)

## SOCIAL STATUS

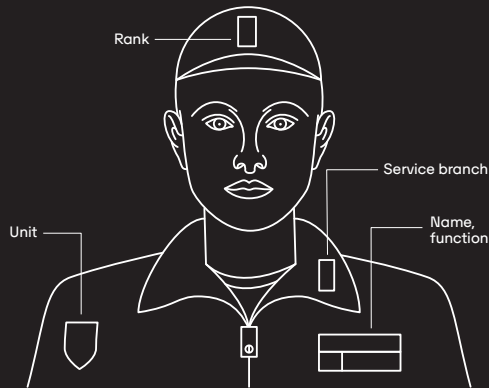

Until the 1990s, a high-ranking position in the army guaranteed social prestige and a well-paying job in the private economy. This interrelationship is becoming less and less important, however. A more independent private economy and outmoded structures within the army are reasons why more and more people are avoiding the military today.

## MARKETING

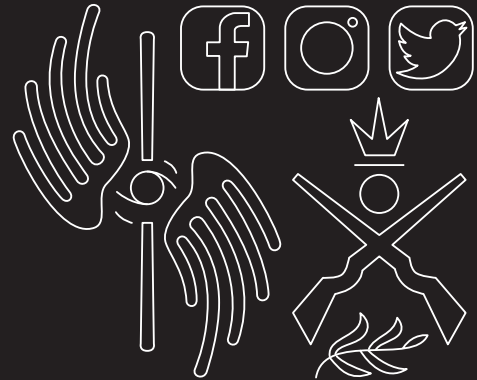

Nearly 20% of all managerial positions in the army are vacant. There are also not enough majors, captains, and soldiers. Among the latter, one position in ten is no longer filled, compared to 2015. An effort is thus being made to make military training more attractive again. In 2017, for example, a social media campaign was launched for this purpose.

## INFORMATION OVERSIGHT



The Swiss army issued a directive in 2007 forbidding the making of electronic recordings while on duty. No photographs, sound recordings, or data storage may be made that depict training or operations or that disrespect the prestige of the uniform as a symbol of the army.

## PRIVATE MILITARIES



Due to the Swiss army's reduction in personnel, private security firms are being called in increasingly often to fill the gap. Currently, these firms secure the army's logistics centers and administrative facilities. The use of private security firms raises the question of their democratic oversight and legitimation.

## MILITARY RESEARCH

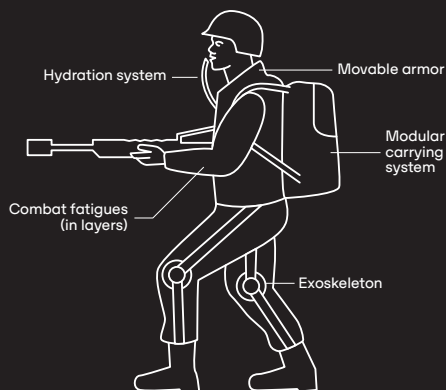

The Swiss army, working with scientists, corporations, and universities, conducts military research. One result of this is a novel set of equipment that will replace current combat fatigues in 2022 and offers more flexibility, endurance, and efficiency.

## CAMOUFLAGE



The newly developed multi-environment camouflage pattern nr. 16 of the army is brown and green. Compared to older patterns, the colors black and red are missing in order to create a good disguise in urban areas as well.

# FEDPOL: SWISS FEDERAL POLICE AGENCY

## Predictive policing using the example of burglaries

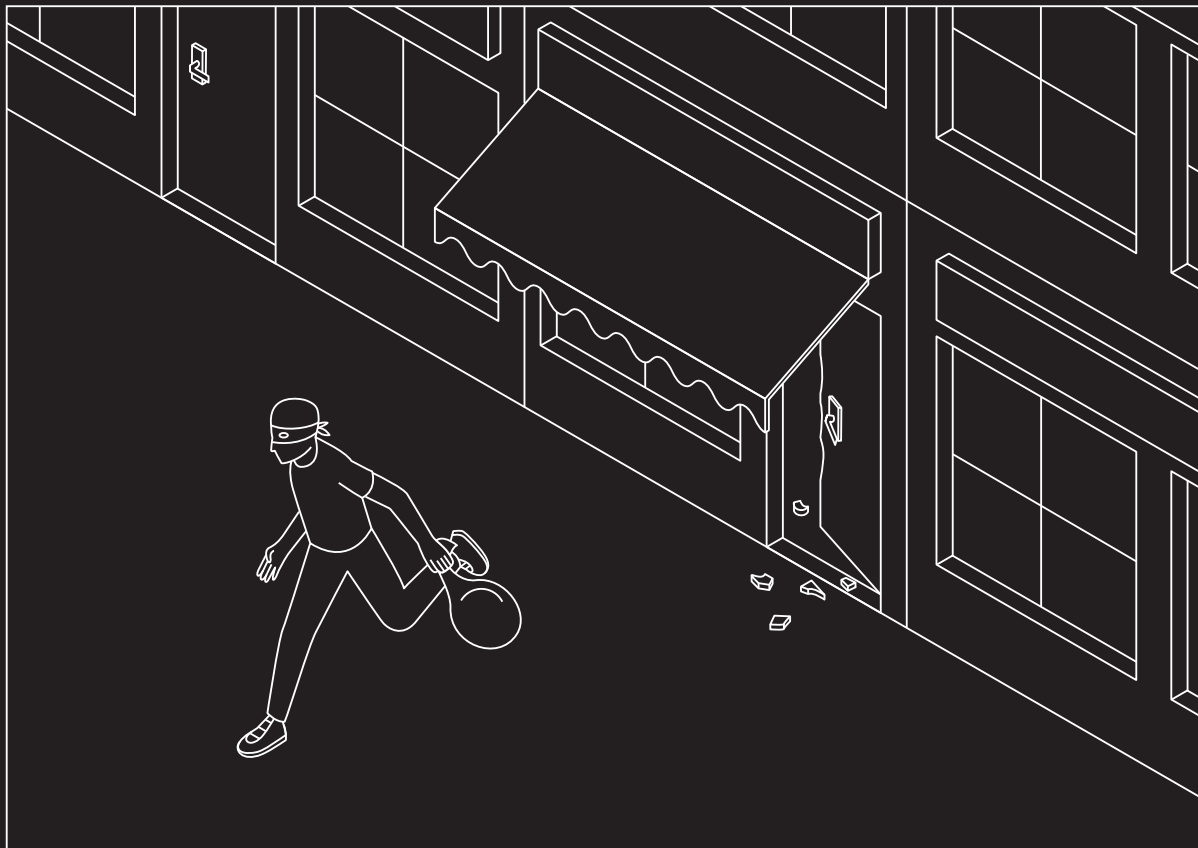

1 Burglary

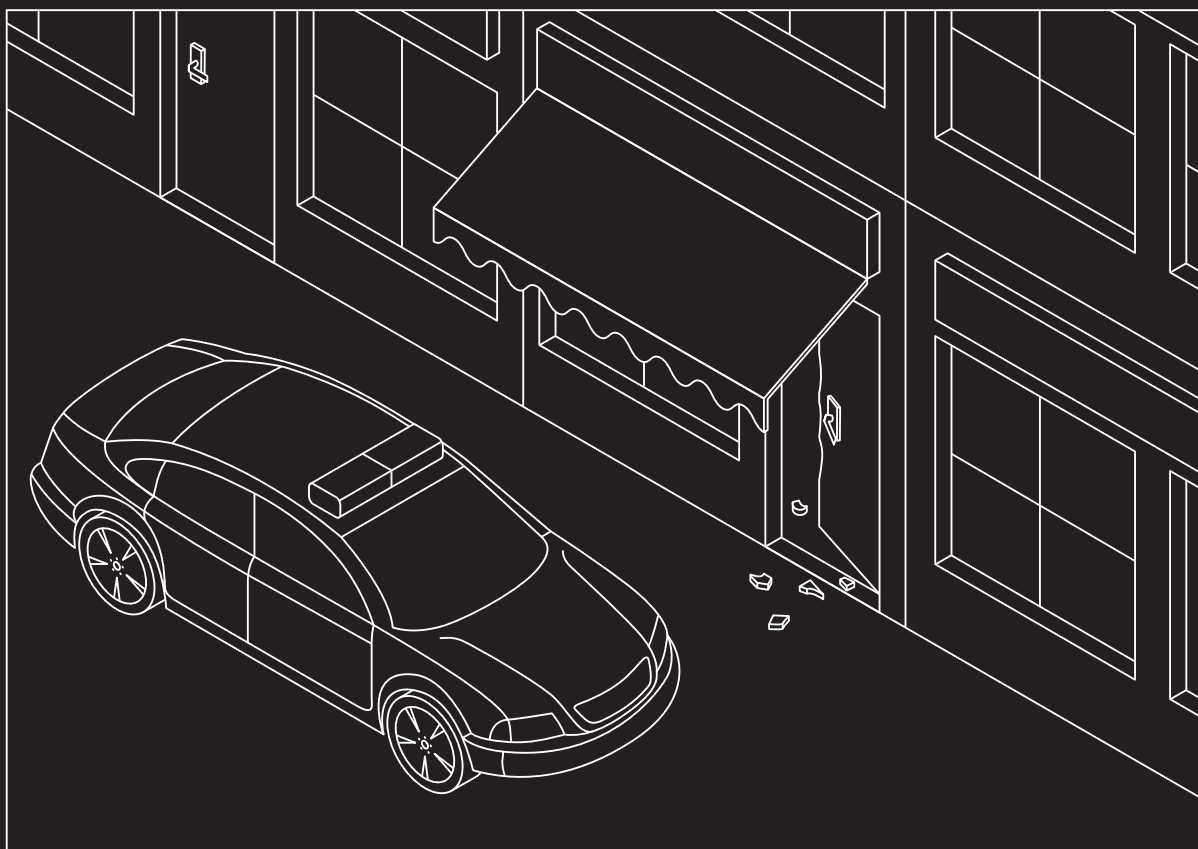

2 Securing  
the scene of  
the crime

To forecast crime, Switzerland began using software known as PRECOBS (Pre-Crime Observation System) in 2015. Its forecasting technique is based on the premise that within a short time, perpetrators will strike repeatedly within an area. Certain police data such as the scene of the crime and its surroundings, a profile of the perpetrator, and the focus of the offense are evaluated. Subsequent offenses are then forecast using "predictive policing" (fig. 1-4). In Switzerland, PRECOBS uses only anonymized data. Critics, however, fear that this data could later be augmented with personal data. The reliability of the software has also been questioned.

3 Prognosis  
using PRECOBS



4 Prediction  
of subsequent  
burglaries

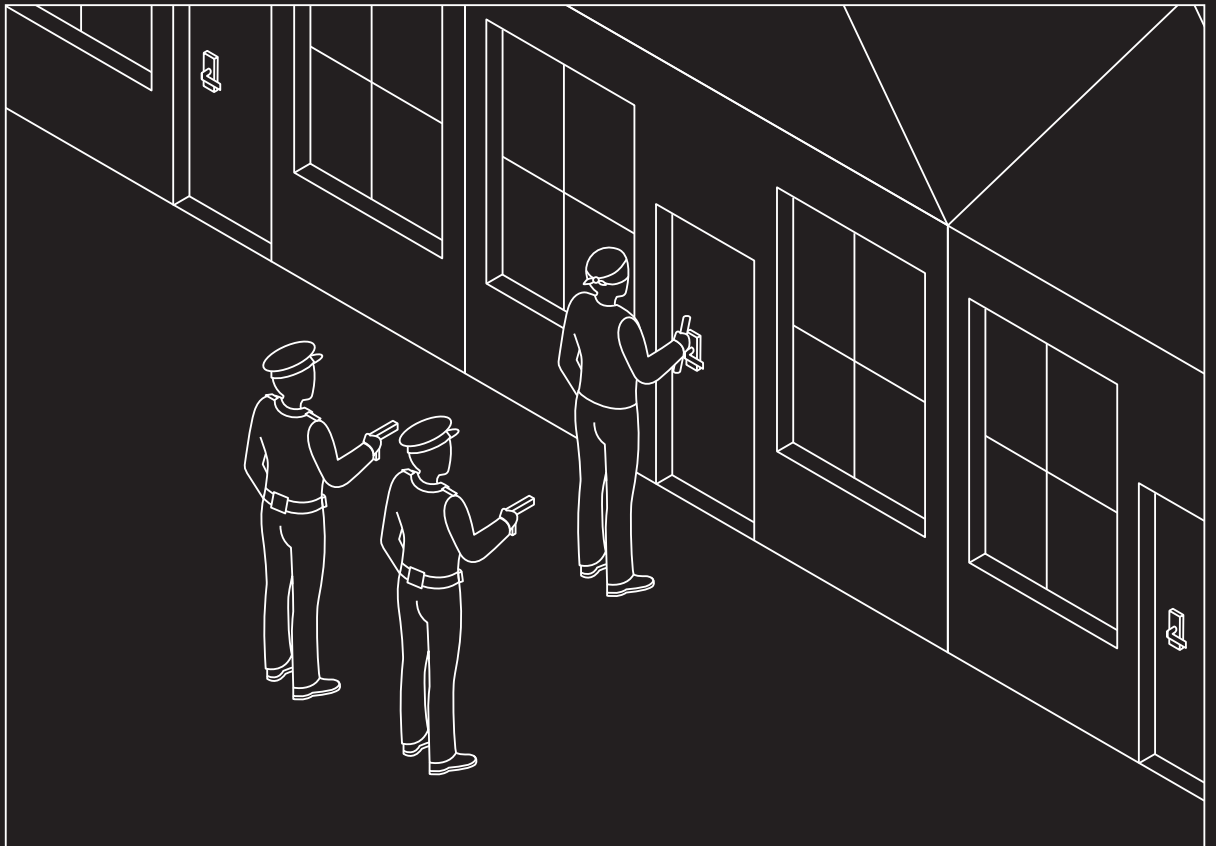

# Trend in the rate of criminal offenses (2012 vs. 2016)

2012, prior to the use of PRECOBS: Ø 9.2 crimes per 1,000 residents



2016, after introducing PRECOBS: Ø 5.6 crimes per 1,000 residents



Criminal offenses per 1,000 residents



>9



7-9



5-7



3-5



>3



## FEDPOL

The Federal Police Agency (Fedpol) is a federal agency of the Swiss Confederation. It is responsible for coordinating police forces in the cantons and for handling foreign police forces' requests for information within the context of cross-border cooperation. This agency conducts investigations in the areas of organized crime, money laundering, and corruption. Swiss identity documents are also within the purview of Fedpol.

### Proportion of criminal offenses by law in Switzerland

Criminal Code .....	78.8%
Controlled Substances Act.....	14.4%
Foreign Nationals Act .....	6.8%

### Offenses against particular parts of the Criminal Code

Property .....	67.5%
Liberty .....	13.6%
Physical integrity.....	5.6%
Public authority .....	2.3%
Sexual integrity .....	1.6%
Other categories .....	9.3%

## INTERPOL



The international criminal-investigation organization INTERPOL was founded in Vienna in 1923. Switzerland was among its founding members. Its goal is to coordinate a comprehensive partnership of all criminal-investigation agencies operating within their national legal framework and in the spirit of the UN's Universal Declaration of Human Rights. It has an annual budget of 113 million Euros and employs a staff of 756 people.

## PRIVATIZATION



In Switzerland, private security companies are being hired more and more often to take on the security duties of police and maintain the public order. Daily 20.000 private security guards

## EUROPOL

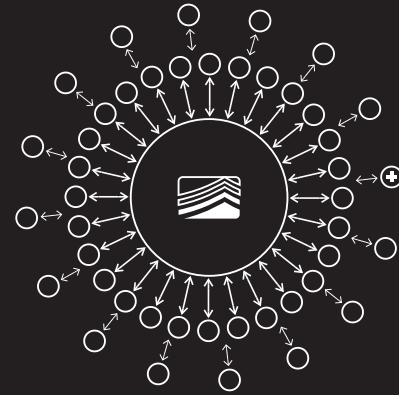

Europol was founded in 1999 as the European law-enforcement agency for preventing and combating international organized crime. Switzerland and Europol have a cooperative agreement that enables the exchange of strategic and operative information as well as specialist expertise.

## CCPD GENEVA AND CHIASSO



The two centers for cooperation between police and customs authorities in Geneva-Cointrin and Chiasso (CCPD) facilitate and expedite cross-border cooperation between police and customs authorities in Switzerland and their counterparts in France and Italy. They promote the exchange of information, co-ordinate joint surveillance measures in border regions, and plan and assist cross-border operations.

Sources (Police and weapons on next page): Mit PRECOBS gegen den Wohnungseinbruch in der Stadt Zürich (Stadtpolizei Zürich, 2013), Polizeiliche Kriminalstatistik (Bundesamt für Statistik, 2018), Jahresbericht FEDPOL 2017 (Eidgenössisches Justiz- und Polizeidepartment, 2017), "Small Arms Survey" (Graduate Institute of International Studies, 2007), "Eine uralte Tradition stirbt aus. Übernahme von Ordonnanzwaffen" (srf.ch, 2017), "Schweizerisches Waffenrecht" (Bundesamt für Polizei fedpol, 2018), Suicide in the World (Int J Environ Res Public Health, 2012).

# SWITZERLAND AND ITS WEAPONS

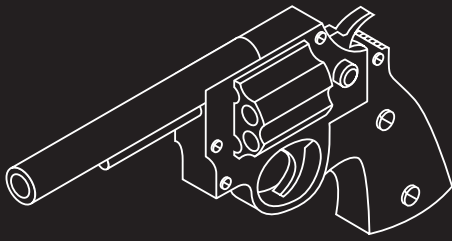

A Firearms

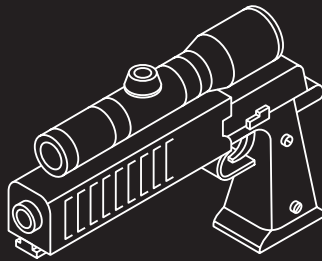

B Compressed air and CO<sub>2</sub> weapons

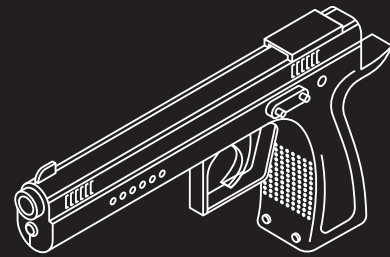

C Imitation, Blank-firing and softair weapons

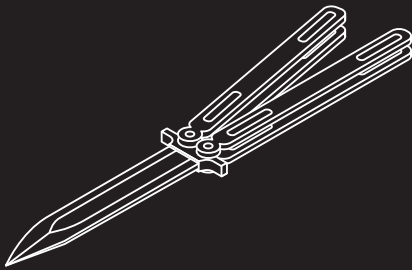

D Knives

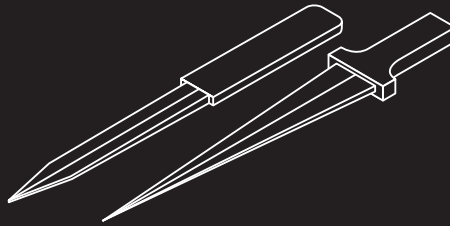

E Daggers

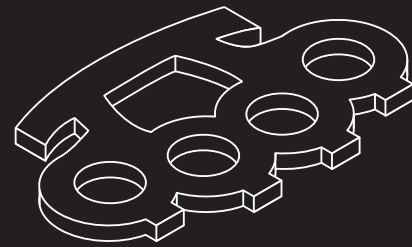

F Devices intended to injure other people

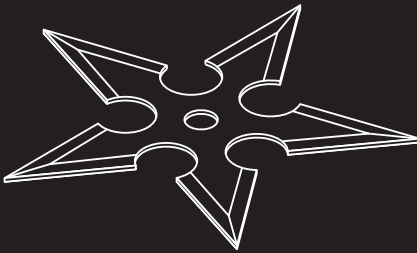

F Devices intended to injure other people

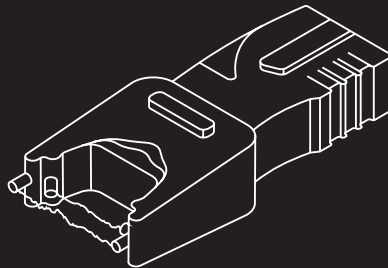

G Electroshock devices, sprays

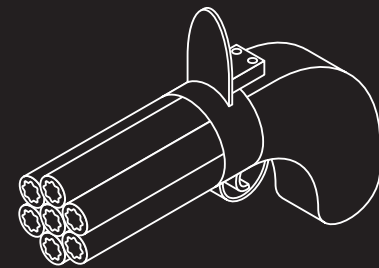

H Antique weapons (special case)

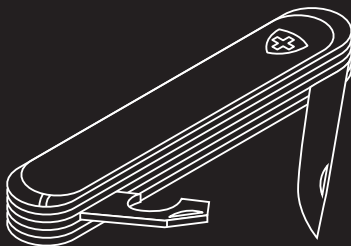

I No weapons (within the meaning of law)

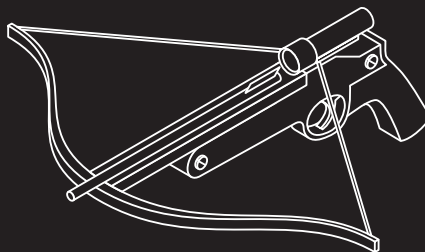

J Weapons addressed by hunting law

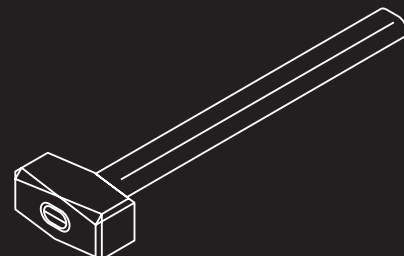

K Dangerous objects

Article 4 of the Swiss Weapons Law defines and categorizes those objects that are officially declared to be weapons (A-K) and that require various forms of authorization in order to be used. The general conditions for acquiring a weapon are that the person must be at least 18 years of age, must not have been declared incapacitated, and must not have a criminal record as a result of violence or actions that endanger public safety. Additionally, there must not be any reason to assume that the person might use the weapon to endanger him- or herself or others.

PRIVATE USAGE OF THE ARMY WEAPON AFTER DUTY

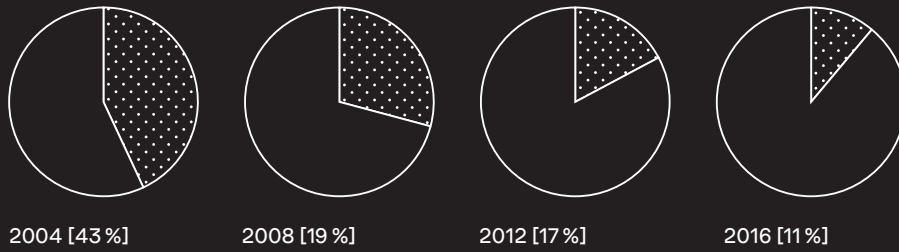

COMPARATIVE OWNERSHIP OF CIVILIAN [FIREARMS PER 100 RESIDENTS]

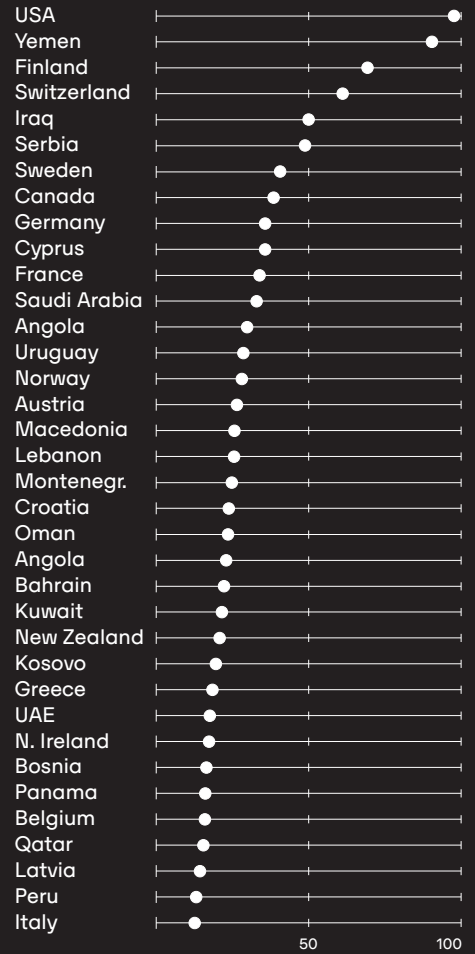

ARMY PPISTOL: SIG P220 / PISTOL 75

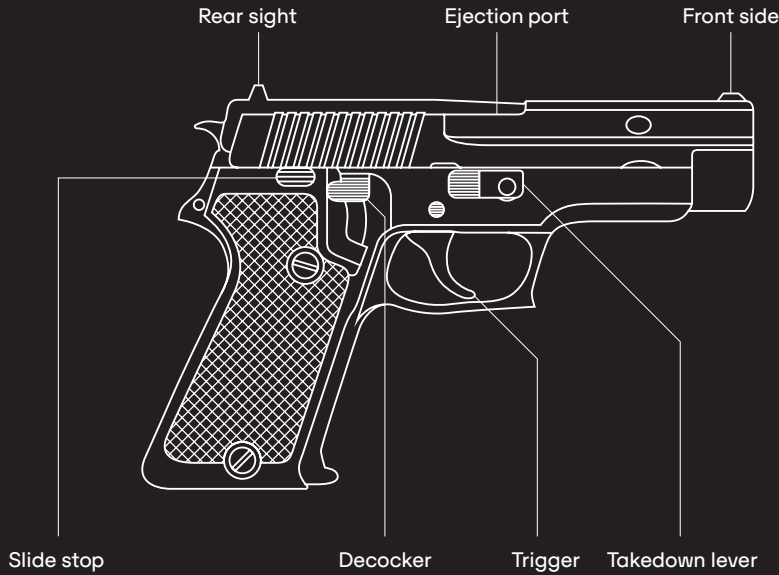

ARMY GUN: SIG 550 ASSAULT RIFLE / STURMGEWHR 90

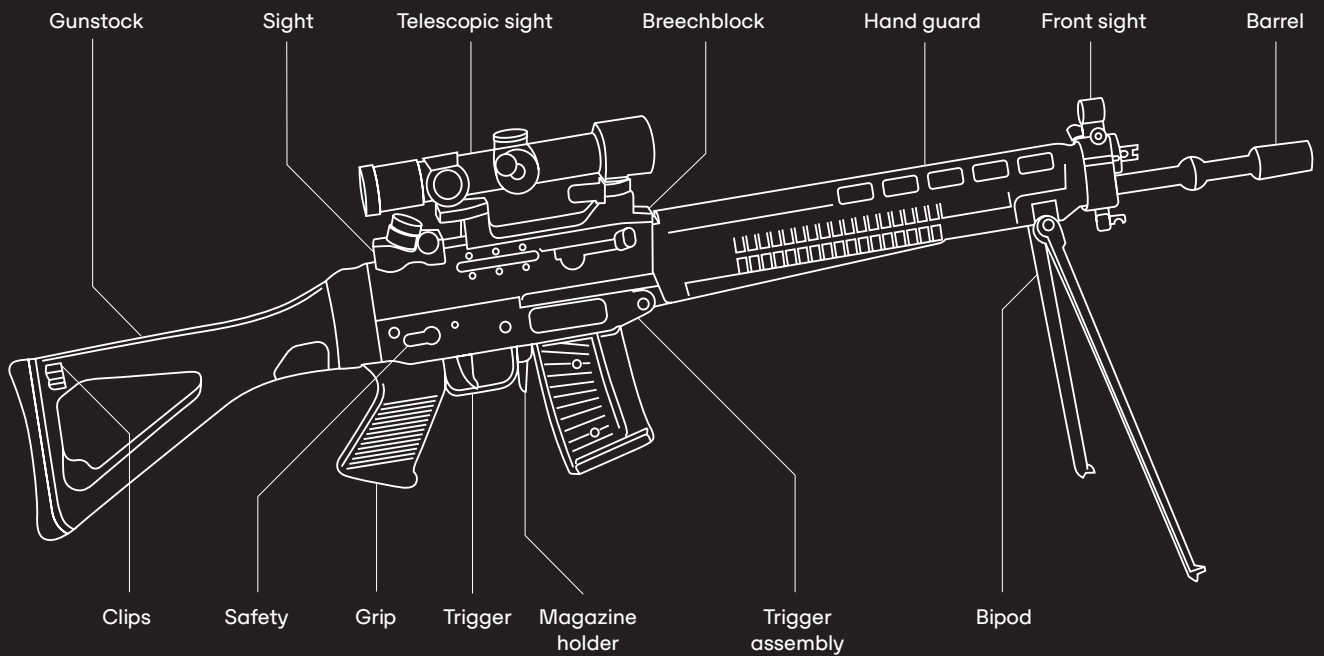

It is estimated that between 2 and 3.4 million firearms are owned by private individuals in Switzerland. This high density of firearms is, among other reasons, due to the fact that the Swiss army allows demobilized soldiers to retain their personal weapon (SIG 550 assault rifle or SIG P220 9 mm pistol) in their private possession. In recent years, however, fewer and fewer soldiers have made use of this option due to newly introduced fees and shooting classes. Conversely, demand by private individuals for obtaining weapons licenses has, admittedly, increased.

# UNDERGROUND CAPITAL: DATA BUNKER

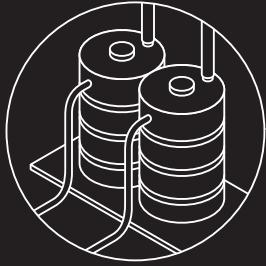

Use of underground water for cooling

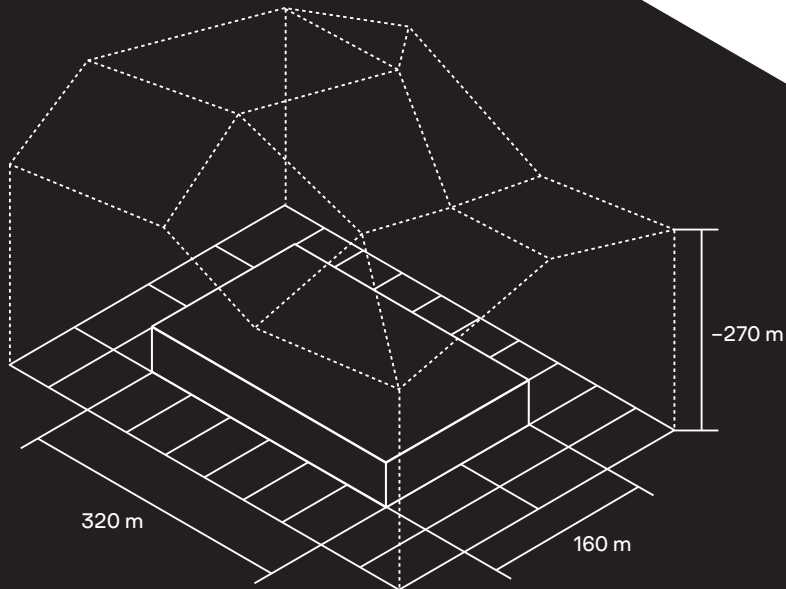
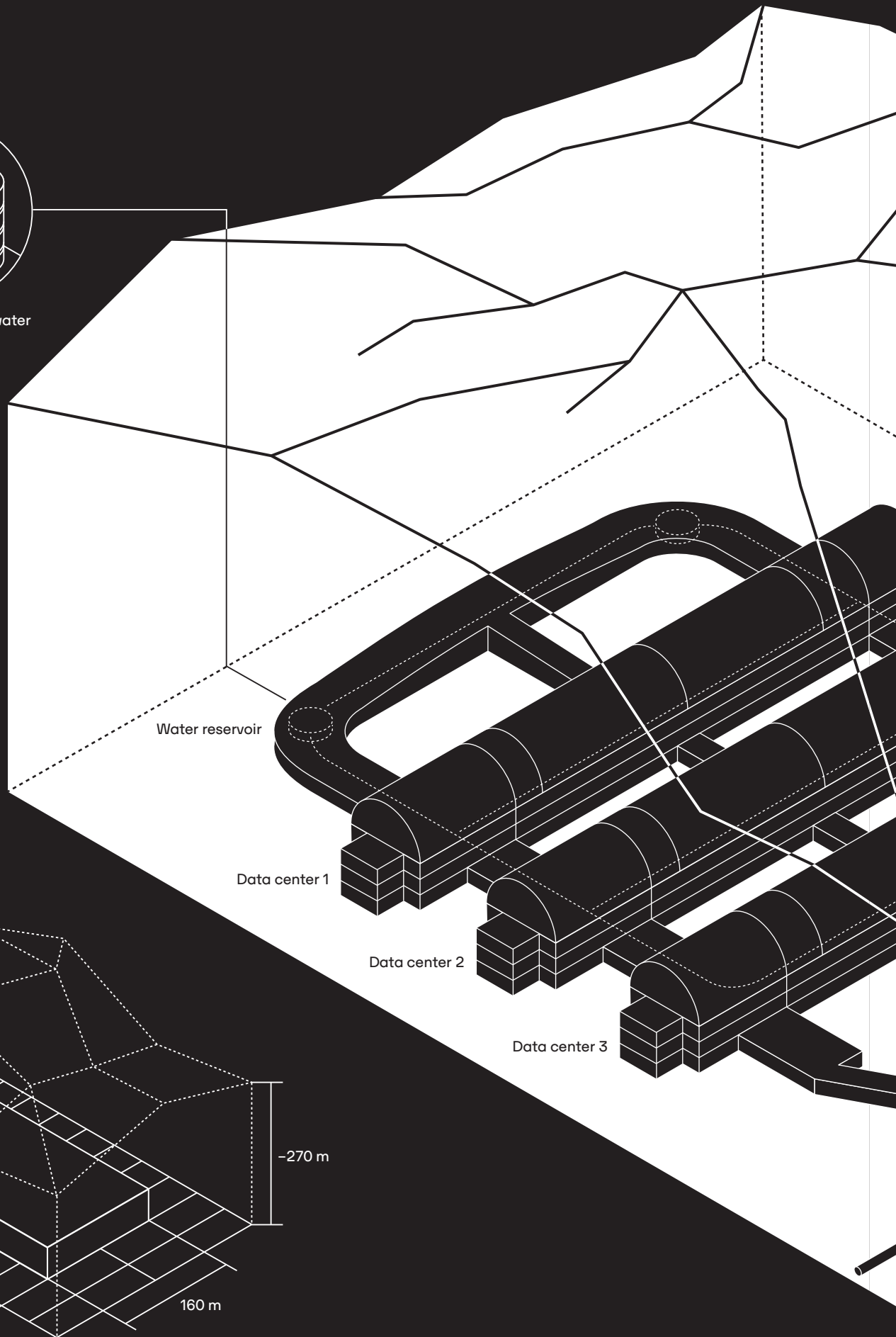

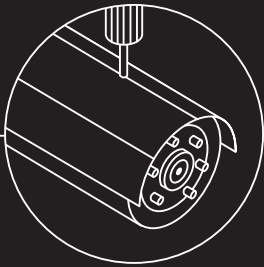

24/7 supervision of all entrance zones

Entrance

Entrance

Diesel reservoirs

Diesel engines

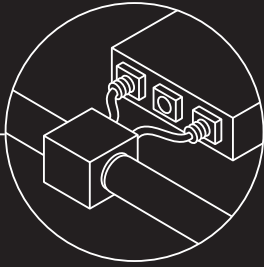

Fast data transfer with internet backbone route

The Deltalis data center is located in a former military bunker, under 1500 meters of mountain. Deltalis is promoting the bunker as the most secure colocation data center in Europe where it stores the data of private banks, pharmaceutical firms, multinational companies and cryptocurrencies on three floors 24/7. Security measures include a redundant design of all critical components (cooling, connectivity and power) and an all-encompassing security system, which starts with the selection of the right staff and ends with the use of the newest security technology.<sup>1</sup>



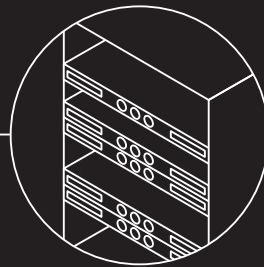

Location.....	Attinghausen
Space.....	10.000 m2
Floors.....	3
Availability.....	99,9999%
Employees Deltalis.....	20
Sold by State in.....	2007



"Private suite servers" in highly save spaces

<sup>1</sup> The company's claim "Hyper Security for a Changing World" has apparently turned against itself. According to various sources, Deltalis has quietly ceased operation as a colocation data center over the course of 2018. The future of the infrastructure remains unclear. However there are speculations that it still will host secure mining and storage facilities for cryptocurrencies by an unnamed party (see: [inside-channels.ch/articles/50697](https://inside-channels.ch/articles/50697) and <https://www.datacenterdynamics.com/news/swiss-data-center-operator-deltalis-leaving-colocation-business/>).

# Deltalis' multi-layer security concept

- |  |   |   |
|--|---|---|
| <p>1 </p> <p>2 </p> <p>3 </p> <p>4 </p> <p>5 </p> | <p><b>VIDEO SURVEILLANCE</b><br/>Video camera surveillance for the complete facility, including outside and inside surveillance of the data center facility.</p> <p><b>ACCESS CONTROL</b><br/>Access is based on personalized profiles and biometric data processing. Separate entrance zones for persons and material for hyper-security.</p> <p><b>30-TON DOORS</b><br/>Doors with a weight of 30 tons can withstand nuclear attacks. Several layers of access security guarantee only authorized persons to access the different parts of the Deltalis area.</p> <p><b>FIRE DETECTION AND SUPPRESSION</b><br/>Fire safe doors to isolate fires. Suppression system using the gas Inergen to ensure less damage as possible for technical devices and human beings</p> <p><b>FLEXIBLE POWER AND COOLING SERVICE</b><br/>The bunker provides its own 730,000 litres of cooling water, which has a constant temperature of 14 degrees. Locally produced hydro-electric power from multiple stations provides energy supply and price stability.</p> | <p>Floor loading ..... 1.200 Kg/m<sup>2</sup></p> <p>Temper. threshold ..... 22°C +/- 4°C</p> <p>Incoming power ..... 11kV with up to 7MW</p> <p>Standard Rack ..... up to 3kVA</p> <p>Cabling ..... Redundant, up to +1MW</p> <p>Room cooling ..... Cold aisle containment</p> <p>Room cooling units ..... 2</p> <p>Cooling ..... Water cooling, Freecooling</p> <p>Specialized Cooling ..... Computer Room Air Condition or InRow cooling</p> <p>Smoke detection ..... Very Early Smoke Detection (VESDA)</p> <p>Fire alarm ..... Fully monitored automated detection and 24/7 alarming</p> <p>1st stage detection ..... HSSD Aspiration (VESDA)</p> <p>2nd stage ..... Alarming with direct connection to authorities</p> <p>3rd stage ..... Gas release, initiated by alarm system with double knock condition</p> <p>Fire rating ..... Fire rated for in excess of 60 minutes</p> <p>Fire protection ..... by zones with redundant detection units</p> <p>IP connection ..... Redundant fibre lines within separate conduits</p> |
|--|---|---|

## Data centers in Switzerland

In response to the exponential growth in data, Switzerland is repositioning itself to focus on the protection of physical and digital data stored in Swiss server farms. The countries reputation for quality, security, stability, respectability and neutrality are a big advantage on the data storage market.

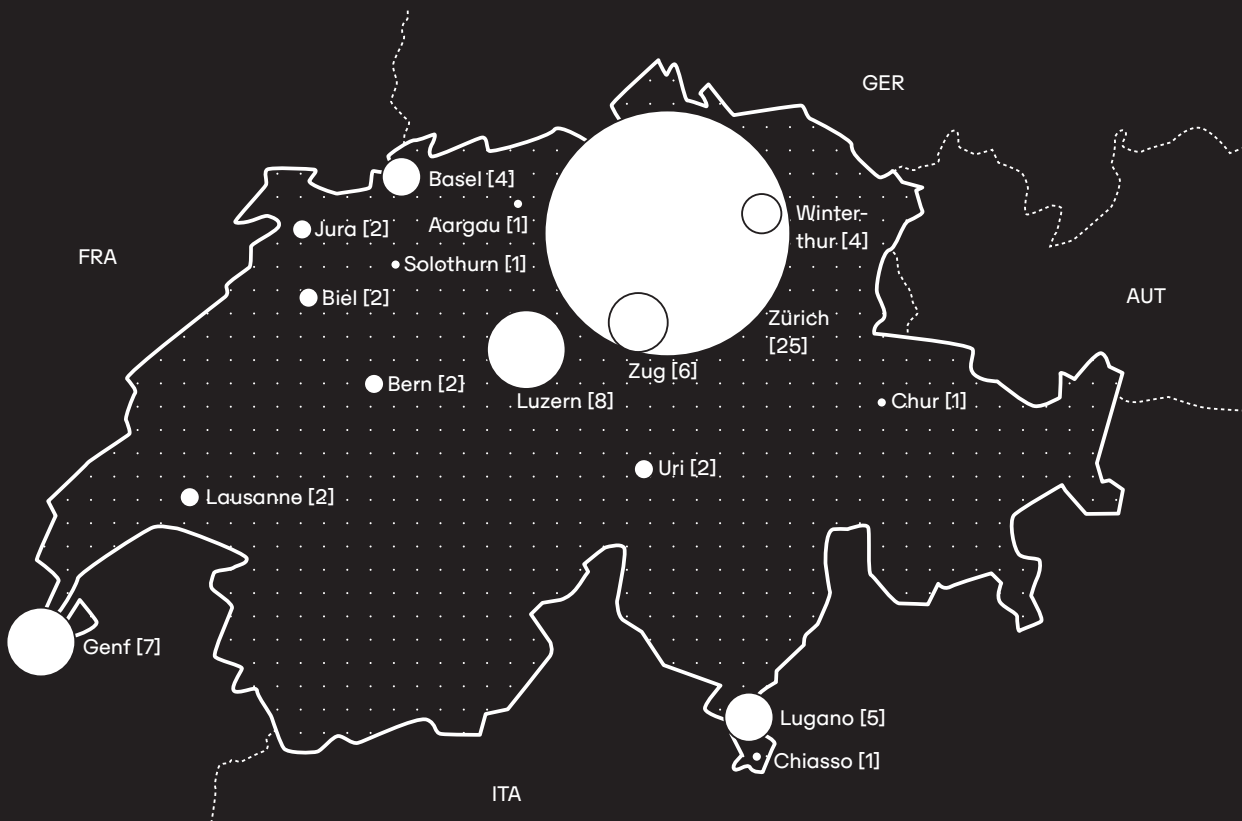

● number of data-centers

Sources: Deltalis Factsheet (Deltalis, 2016), Daten im Kommandobunker (Tagesanzeiger, 2012), datacentermap.com/switzerland (2018), Hypersecurity for a changing world (deltalis.com, 2017)



# WEATHER SECURITY AT ZURICH AIRPORT

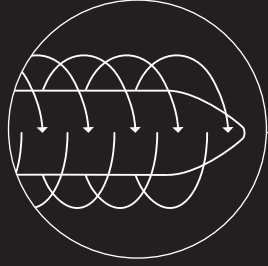

Aircraft measure data on turbulence

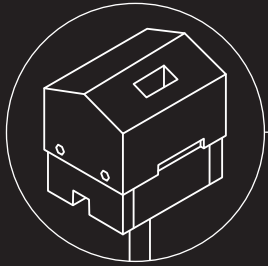

Ceilometer measures the cloud ceiling

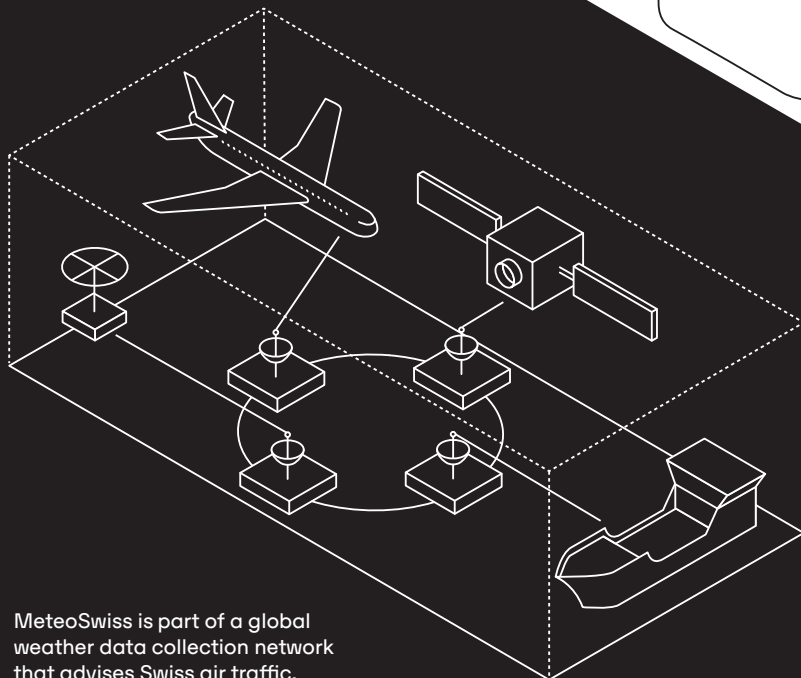

MeteoSwiss is part of a global weather data collection network that advises Swiss air traffic.





MeteoSwiss is responsible for the meteorological component of air-traffic safety. Since June 2014, 200 of its 350 employees in Switzerland are stationed at Zürich Airport. Here, forecasts are produced, research is done, and meteorological data from the whole country is processed.

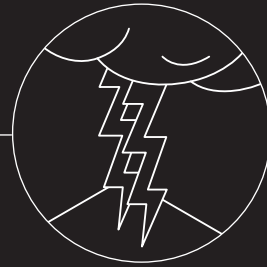

Weather warnings determine flight paths

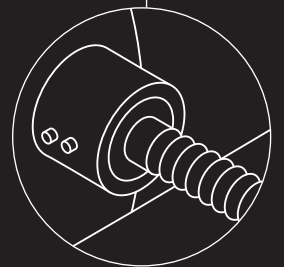



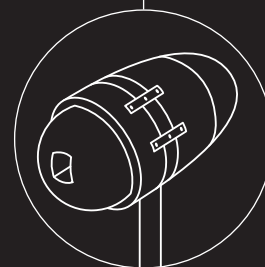

Weather forecasts influence amount of fuel



Transmissometer measures runway visibility



# Systems for measuring weather data for air traffic

- 1  **WEATHER RADAR**  
Every 2.5 minutes, five stations measure precipitation such as rain, snow, and hail from up to 200 km away. Radar allows thunderstorms to be predicted at short notice.
- 2  **GROUND NETWORK**  
Across the country, 160 ground stations automatically measure up to 20 weather parameters every ten minutes.
- 3  **NAKED-EYE OBSERVATION**  
Certain parameters, such as cloud cover and cloud type, are better recognized by people than by measuring devices. Nearly 500 observers assess the weather daily.
- 4  **WEATHER BALLOONS**  
Twice a day, balloons are used to measure temperature, air pressure, and wind speed, radioing the data to ground stations from an altitude of up to 30 km.
- 5  **WEATHER CAMERAS**  
MeteoSwiss operates 35 cameras along the main Swiss flight paths. Every ten minutes, these deliver a panorama shot of the weather.

# COSMO weather model

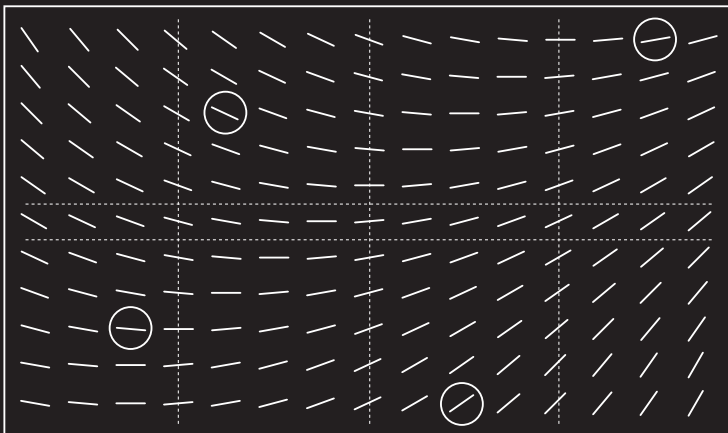



COSMO-2 calculates forecasts for the Alpine region, offering predictions for up to 33 hours in advance. It is based on the larger COSMO-7 model for western and central Europe, which uses observations from 8,000 aircraft, 28,000 weather stations, and information from 1,000 wind profiles. The COSMO models are calculated at the high-performance computing center in Lugano, where the Buin supercomputer performs 5 trillion operations per second.

# Low-level significant weather chart

The low-level significant weather chart is used in flight preparation. It describes weather conditions, focusing on weather phenomena occurring in the meteorologically complex Alpine region that are potentially dangerous to aircraft.

A selection of symbols for bad-weather alerts

-  ..... Region of bad weather
-  ..... Weather zone
-  ..... Zone of turbulence
-  ..... Rain
-  ..... Showers of rain
-  ..... Freezing rain
-  ..... Snow
-  ..... Showers of snow
-  ..... Snow Grains
-  ..... Showers of snow pellets
-  ..... Thunderstorm with rain
-  ..... Fog
-  ..... Freezing fog
-  ..... Smoke
-  ..... Blowing snow
-  ..... Drifting snow
-  ..... Ice pellets
-  ..... Moderate turbulence
-  ..... Strong turbulence
-  ..... Light icing
-  ..... Moderate Icing
-  ..... Severe Icing
-  ..... Haze
-  ..... Mist
-  ..... Snow level
-  ..... Moderate or severe mountain waves
-  ..... Duststorm



# CYBERSECURITY: ATTACKS AND TARGETS

## Social engineering and surveillance • Target: private individuals

### WEBCAM HACKING/CAMFECTING

----- Using a computer virus  
to commandeer a webcam



SPAM E-MAIL/DAY RECEIVED: SWITZERLAND

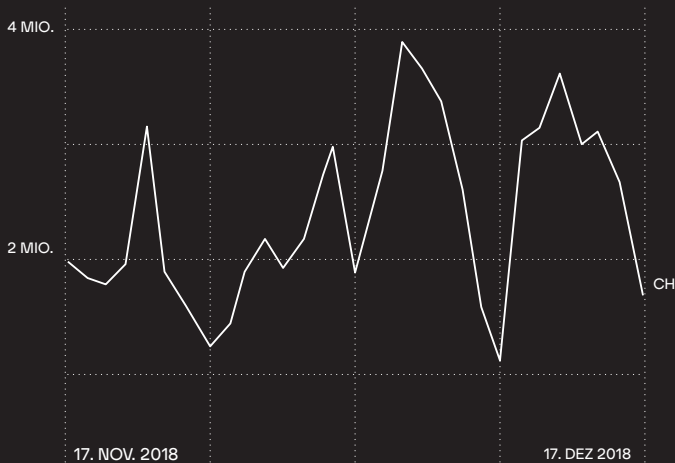

SPAM E-MAIL/DAY RECEIVED: CHINA VS. USA

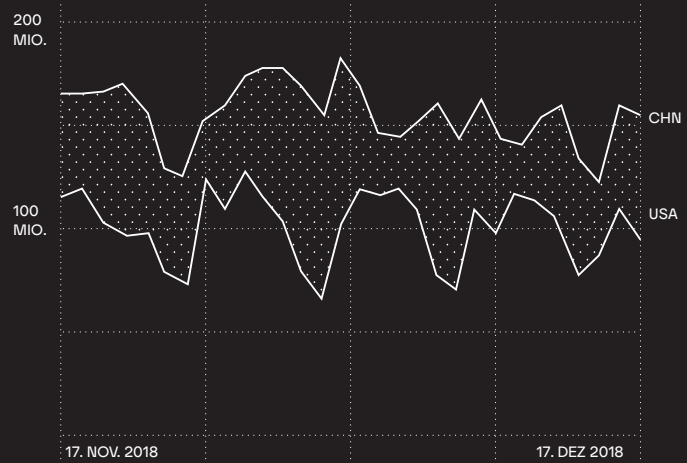

Cybercriminals use social engineering to deceive and manipulate their victims and get at their confidential data or money. A familiar method is phishing, in which spam e-mail leads users to websites that appear trustworthy but that require the user to enter, for example, credit-card information for the sake of "verification." Another type of cybercrime is camfecting, in which the user's webcam is controlled remotely and compromising images or video are used to blackmail him or her. In 2014, hackers breached thousands of webcams around the world, including 141 in Switzerland.

# Cyber-terrorism • Target: critical infrastructure

## THE WATER SUPPLY

----- Attack via network connections

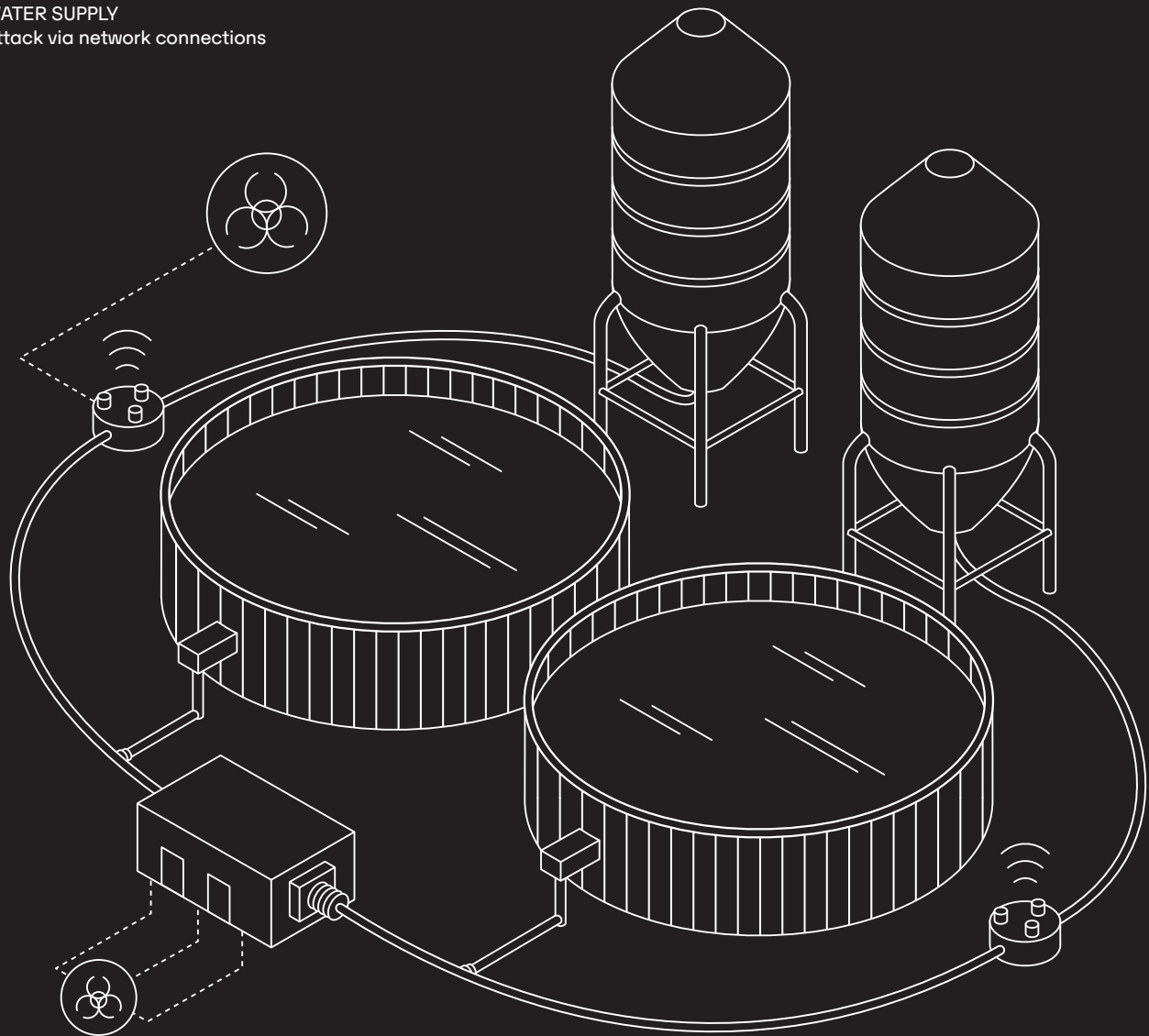

## VULNERABLE INDUSTRIAL SYSTEMS



Dichte der über das Internet zugänglichen Industrie-Kontrollsysteme in der Schweiz

## CYBERATTACKS ON INDUSTRIAL SYSTEMS

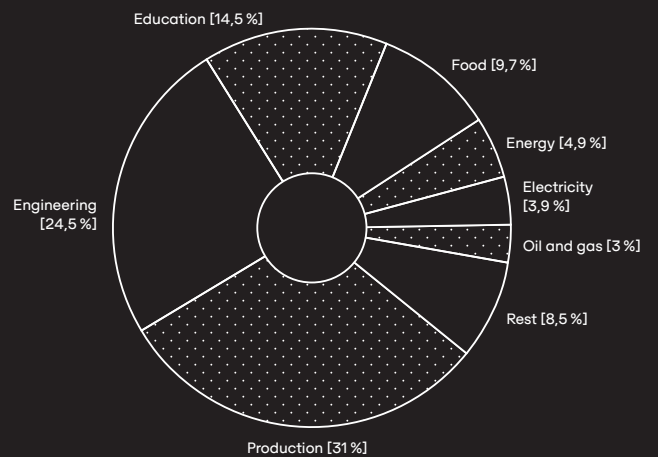

Cyberterrorism has the goal of damaging a country's infrastructure (energy, water, industry, etc.) and destabilizing its society. In Britain, one in three shutdowns of infrastructure can already be attributed to a cyberattack. Switzerland's extensive digitalization makes that country vulnerable to cyberterrorism as well. Initial safeguards, planned in 2012, are to be implemented by 2022 with the help of a national strategy.

Sources: MELANI [Melde- und Analysestelle Informationssicherung] Halbjahresbericht [Semi-Annual Report] 2018; National Strategy for the Protection of Switzerland against Cyber-Risks (Federal Council, 2018); Cyberrisk Survey Report (Kessler, 2018); Cyberthreat und DDoS-Report (Kaspersky Lab, 2018); APT Case Ruag (govcert.ch, 2016).

# Botnets • Target: corporations and citizens

## DDoS BOTNET

----- Network of infected PCs  
 Attack by overload

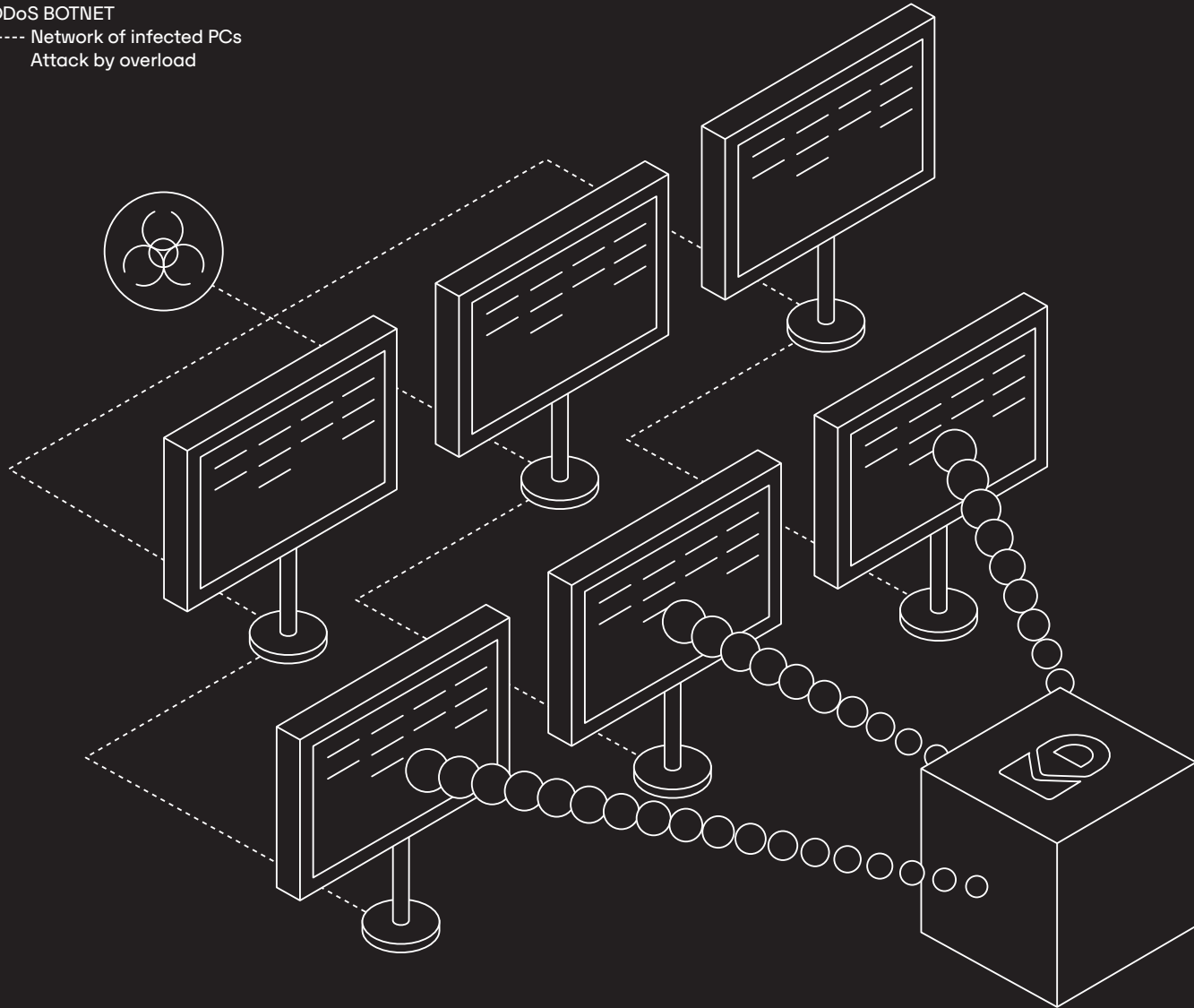

## DDoS: ATTACKERS AND TARGETS (TOP 3)

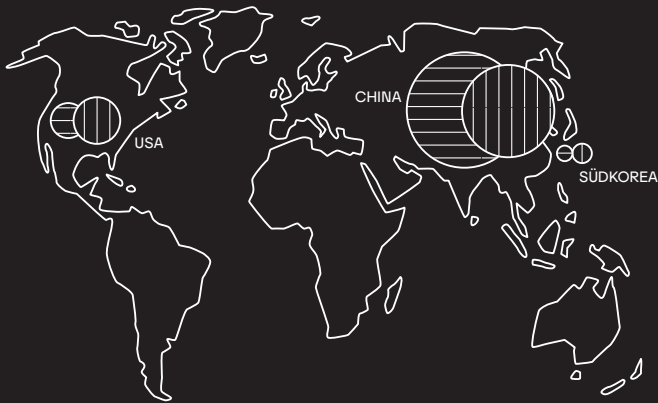

○ Number of attackers ○ Number of victims

## RELEVANCE OF CYBER-RISKS IN COMPANIES

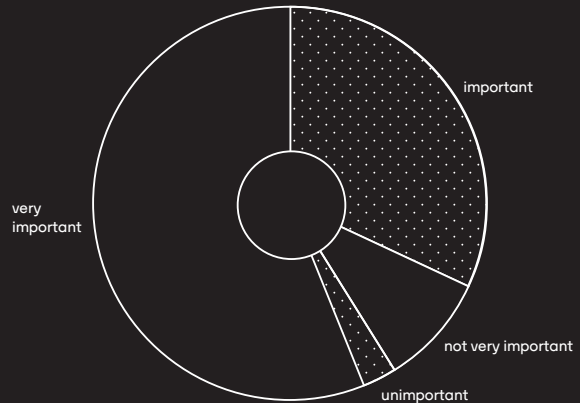

○ How much importance does your company attach to cyber-risks?

Swiss corporations have often been the target of DDoS (distributed denial of service) attacks. These have the aim of compromising the availability of computer systems. Generally, botnets (a very large number of infected computers) are deployed to, for example, cripple competitors' websites by continually penetrating them. Botnets can also be deployed for political purposes, such as disrupting rival communications or helping to shape public opinion through automated social media campaigns.

# Cyber-espionage • Target: states and corporations

RUAG DATA THEFT  
 ----- Data leak from system  
 infiltration

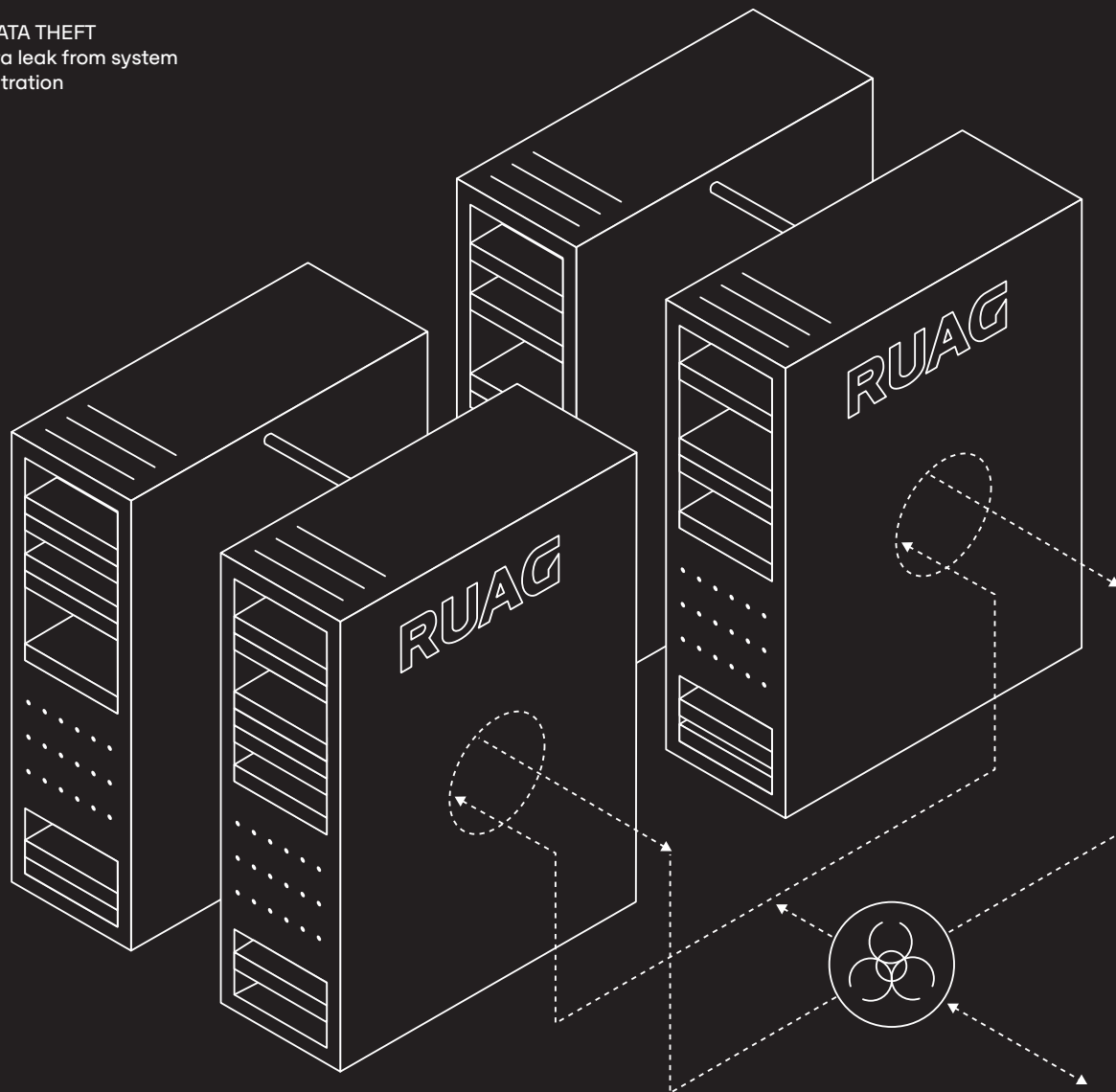

RUAG: AMOUNT OF DATA STOLEN

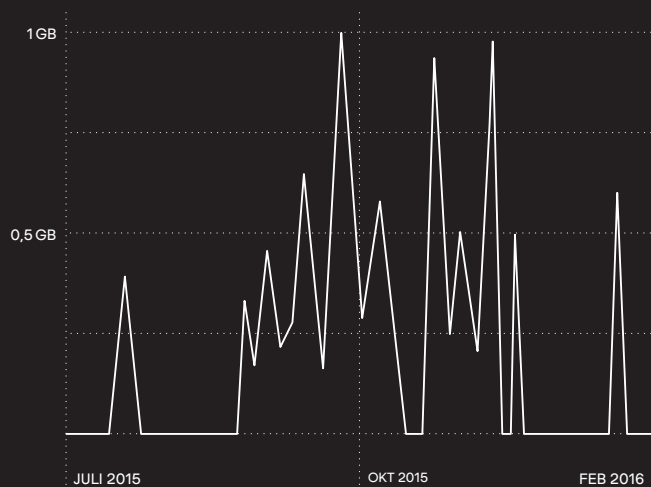

CYBER-ESPIONAGE BY SECTOR, GLOBAL

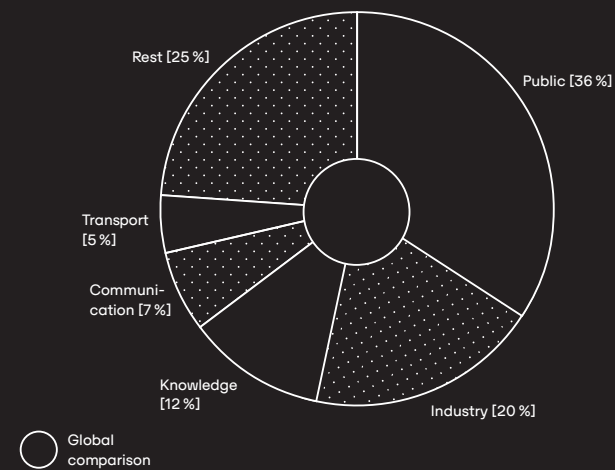

Cyber-espionage is the unauthorized removal of information from states or corporations via electronic networks. One of the most spectacular cases of espionage in Switzerland took place between 2014 and 2015, when suspected Russian hackers used a trojan to steal data from defense contractor RUAG over a period of 14 months. In Switzerland, the Federal Intelligence Service, the army, the police, and the Reporting and Analysis Centre for Information Assurance cooperate on a national and international level to prevent and resist cyber-espionage.



## IMPRESSUM/IMPRINT

Dieses Handbuch erscheint begleitend zur Ausstellung «Salvatore Vitale. How to Secure a Country» in der Fotostiftung Schweiz vom 23. Februar bis 26. Mai 2019.

This manual accompanies the exhibition "Salvatore Vitale. How to Secure a Country" at Fotostiftung Schweiz from 23rd of February until 26th of May 2019.

Herausgegeben von der Fotostiftung Schweiz/Edited by Fotostiftung Schweiz

Texte/Texts  
Lars Willumeit  
Salvatore Vitale

Fotografien/Photographs:  
Salvatore Vitale

Datenvisualisierungen, Informations- und Handbuch-Gestaltung/Data visualization, information and manual design:

Offshore Studio, Zurich  
(Isabel Seiffert & Christoph Miler)

Lektorat, Korrektorat/Editing, proofreading

Lars Willumeit  
Salvatore Vitale  
Sascha Renner  
Peter Pfrunder  
Joanna L. Cresswell

Ausstellungskurator/  
Exhibition curator:  
Lars Willumeit

Projektleiter/Project Manager:  
Sascha Renner,  
Fotostiftung Schweiz

Druck/printing:  
Centro Stampa Ticino

Auflage/print-run:  
4 000